

SensyTemp TSP300-W WirelessHART Temperature sensor with Energy Harvester

Autonomous wireless temperature measurement

Measurement made easy



Powered by process temperature

Backup via standard lithium battery with long service life

Fast and easy commissioning

No battery replacement necessary with optimum operation

Intuitive and intelligent operating concept

Configuration on the temperature sensor itself
Without external power supply

Heavy duty model for harsh process operation

WirelessHART

Approvals

— ATEX, IECEx

SEITA

Soluciones en Instrumentación,
Automatización y Control Industrial

www.seita.com.co

Power and productivity
for a better world™



SensyTemp TSP300-W WirelessHART Temperature sensor with Energy Harvester

Introduction

Autonomous temperature measurement

In the past, temperature measurement devices always required cables to supply power and transmit signals. The cabling was often very laborious, taking up a lot of time and incurring high costs, particularly if larger distances had to be covered, disturbances circumvented, and safety aspects considered.

The costs for the cabling often exceeded the costs of the measuring device itself, which ultimately led to temperatures not being measured at all. This meant accepting compromises in terms of optimum process control.

The introduction of wireless signal transmission brought about a reduction in the costs of cabling. Nevertheless, a cable connection was still required to supply power to the measuring device.

Battery operation is a possible alternative. However, maintenance intervals for battery replacement must be strictly observed to guarantee fully functioning measurement.

The SensyTemp TSP300-W temperature sensors enable completely independent temperature measurement. There is no longer any need for cabling or battery replacement, and installation and maintenance costs are drastically reduced or even eliminated completely. No additional external energy is needed, and ensuring compliance with safety requirements is much easier. The result is an increase in system performance, improved effectiveness, and increased safety.



Fig. 1

System structure

TSP temperature sensors are contact thermometers which, through contact with the measuring medium, are brought to the temperature of the medium.

The sensor is made up of modular components. The centerpiece is the measuring inset, which houses the actual sensor element for temperature measurement in its tip.

The thermowell surrounds the measuring inset and establishes the contact to the measuring medium. It ensures that the measuring inset can be replaced in a self-contained process and protects the inset against mechanical and corrosive influences of the process. The material and geometry of the thermowell must meet the process requirements (e.g. medium composition, measuring temperature, pressure).

The process connection is the mechanical interface between the process and the temperature sensor. The extension tube mounted on this interface creates the required distance to the connection head to protect it against overheating. The temperature gradient between the process temperature and the ambient temperature in the extension tube is converted into electrical energy by an Energy Harvester. An integrated micro-thermal generator (micro TEG) supplies the power for this. The electrical energy required is generated from the temperature difference between the process pipe and the ambient temperature by applying the Peltier effect. The micro TEG is therefore the ideal solution for using wireless WirelessHART temperature sensors as completely autonomous units in most processes. Many processes involve sufficient process heat to enable a "complete power supply" by the micro TEG. A built-in high-performance battery buffers potential process-driven power failures of the micro TEG. The adjustable connection head houses the transmitter electronics that convert the small output signal from the sensor elements into a WirelessHART signal.

Operating principle

Resistance thermometers and thermocouples are used as sensor elements.

Platinum has established itself as the resistance material in resistance thermometers due to its excellent chemical resistance and its characteristic curve quality.

Pt100 is used in most cases; a platinum resistance with 100 Ω at 0° C. The temperature coefficient α is 0.003851/K. Measuring ranges and accuracy classes are defined in IEC 60751.

There are two different Pt100 sensor element designs. Wire wound resistors (WW) consist of a bifilar wound platinum wire embedded in a ceramic capillary in ceramic powder. As the platinum wire is embedded flexibly in this design, there is almost no mechanical tension to restrict the measuring range. Measurements of -196 ... 600 °C (-320.8 ... 1112 °F) are possible, although this design is relatively sensitive to external mechanical influences.

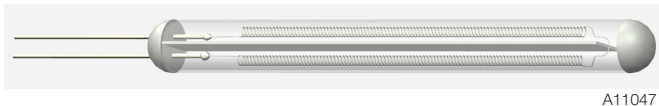

Fig. 2: Wire wound resistor (WW)

In thin film resistors (TF), a ceramic substrate is sputtered with platinum. The resistance wire is then sealed with a glass coating. As the platinum layer is permanently bonded with the substrate in this design, due to material tensions the measuring range for the most common types is -50 ... 400 °C (-58 ... 752 °F). Thin film sensors are very small and light. They are particularly resistant to external mechanical influences and can be installed in very short temperature-sensitive lengths.



Fig. 3: Thin film resistor (TF)

Thermocouples use the Seebeck effect. This creates thermal voltages dependent on two different, conductive alloys at different temperatures.

The level of the thermal voltage depends on the alloy combination and the temperature difference of the connection points.

Various types of thermocouples cover a measuring range of 0 ... 1100 °C (32 ... 2012 °F) for industrial thermocouples. IEC 60584 describes both the characteristic curves and the accuracy classes of the most common types. In the USA, ANSI MC96.1, which is very similar, is used.

Thermocouples are extremely stable from a mechanical perspective and in an optimized design, have very short response times. However, resistance sensors provide greater accuracy.



Fig. 4: Thermocouple

SensyTemp TSP300-W WirelessHART Temperature sensor with Energy Harvester

General Information

As contact thermometers have to be brought to the temperature of the measuring medium, correct installation is particularly important for the quality of the measurement. The best results with regard to accuracy and response time are achieved when the sensor element is located at the point of the greatest medium velocity, i.e. the center of the pipe. To eliminate heat conduction errors to the greatest extent possible, the immersion length must be 10 ... 15 times the thermowell diameter. Heat conduction errors arise when the ambient temperature reaches the sensor element via the thermowell.

The sensor built in to the tip of the thermowell should be as evenly bathed in medium as possible.

Installation positions 2 and 3: The thermowells are therefore usually installed at a 90° angle. The thermowell tip, i.e. the sensor, should be in the middle of the pipe.

Installation positions 1 and 5: To meet the requirement for central installation of the sensor, thermowells can also be installed in elbow pipes vertically or at an obtuse angle to the flow direction.

Installation position 4: Indirect measurement of the medium temperature via the pipe surface is a further option in addition to immersion measurement. Indirect measurement is somewhat less accurate than measurement in the pipe. Pipe wall thickness, pipe material and other parameters can influence the measuring result.

For surface measurement, ensure optimum contact between the sensor element and the surface and that the sensor element is insulated against the ambient temperature by means of suitable insulating material.

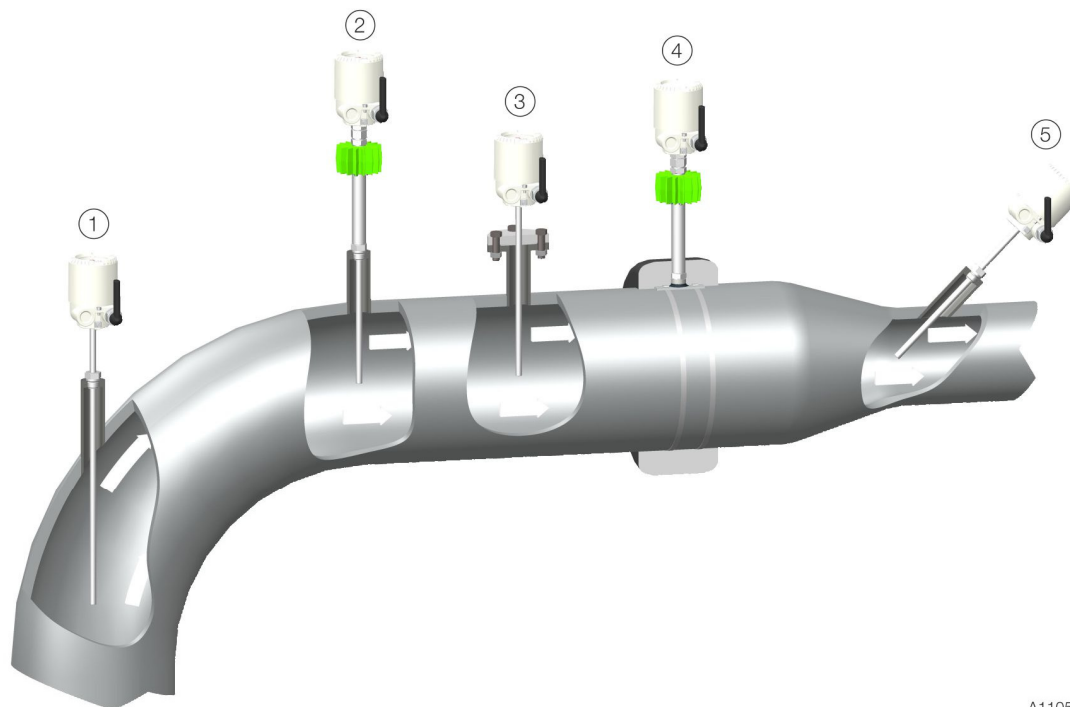

In conjunction with an Energy Harvester, the temperature sensor is completely location-independent within its range in this measuring method as neither wiring nor difficult to install welded spuds are required.



A11050

Fig. 5: Installation positions

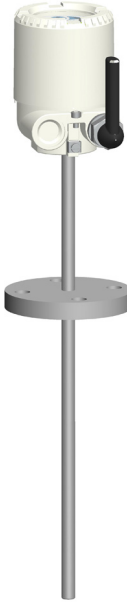
Types of temperature sensor – overview

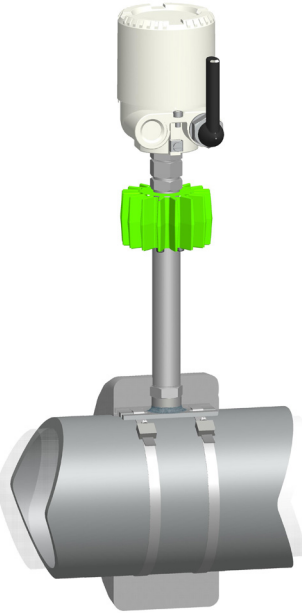
Type	TSP311-W	TSP321-W	TSP331-W	TSP341-W
	 <p>A11052</p>	 <p>A11053</p>	 <p>A11054</p>	 <p>A11055</p>
Energy Harvester	●	—	●	●
LCD display	●	●	●	●
Design	Measuring inset, thermowell, extension tube with thermowell connection, process connection, connection head, WirelessHART electronics-			
Process connection	For installation in an existing thermowell	Screw-in thread, flange, weld-in socket, compression fitting	Screw-in thread, flange, weld-in socket	Surface mounting
Thermowell	None	Welded	Drilled	None

SensyTemp TSP300-W WirelessHART Temperature sensor with Energy Harvester

Built-in sensors – specifications

Temperature ranges and pressure limits

Designs, materials, ranges, limit values			
Storage / transportation temperature	-50 ... 85 °C (-58 ... 185 °F)		
Process	In the process, the values specified generally deviate significantly downwards due to the influence of viscosity, medium velocity, pressure and temperature.		
Resistance thermometer Pt100	Thin film resistor (TF)	-50 ... 400 °C (-58 ... 752 °F)	
	Wire wound resistor (WW)	-196 ... 600 °C (-320.8 ... 1112 °F)	
Thermocouples	Type K	-40 ... 1200 °C (-40 ... 2192 °F)	
	Type N	-40 ... 1200 °C (-40 ... 2192 °F)	
	Type J	-40 ... 750 °C (-40 ... 1382 °F)	
	Type E	-40 ... 950 °C (-40 ... 1742 °F)	
Thermowell materials	1.4404 / 316L	-196 ... 600 °C (-320.8 ... 1112 °F)	
	1.4571 / 316Ti	-196 ... 800 °C (-320.8 ... 1472 °F)	
	2.4819 / Hastelloy C 276	0 ... 1100 °C (32 ... 2012 °F)	
	2.4816 / Inconel 600	0 ... 1100 °C (32 ... 2012 °F)	
	2.4360 / Monel 400	0 ... 550 °C (32 ... 1022 °F)	
	1.0460 / C22.8	0 ... 1100 °C (32 ... 2012 °F)	
	1.4876 / Incoloy 800	0 ... 1100 °C (32 ... 2012 °F)	
	1.4539	0 ... 1100 °C (32 ... 2012 °F)	
	1.7335	0 ... 540 °C (32 ... 1004 °F)	
For stainless steel thermowells with coating	ECTFE coating	0 ... 120 °C (32 ... 248 °F)	
	Tantalum coating	0 ... 200 °C (32 ... 392 °F)	
	Pressure	Tubular thermowells	40 bar (4 MPa) (580 psi)
		Drilled thermowells	700 bar (70 MPa) (10152 psi)
			or according to calculation by ABB ¹⁾

1) ABB performs thermowell calculations according to ASME PTC 19.3 / TW 2010 or according to the calculation method (Dittrich / Kohler) often required in central Europe. This requires the specification of the maximum flow velocity of the measuring medium (m/s), the density (kg/m³), the process temperature (°C), and the process pressure (bar). The thermowell dimensions (mm) required are the installation length, tip diameter, bore diameter and the desired material.

Measuring inset

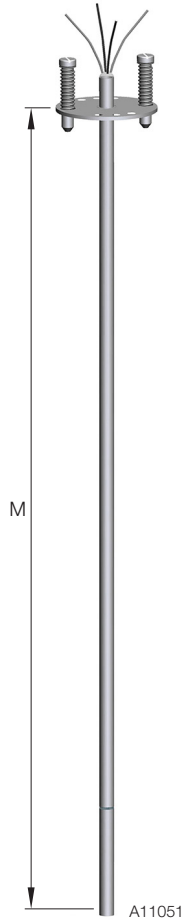

Fig. 6: Measuring inset

Design	
Dimensions ³⁾	For type 311-W: $M = U + K + 25 \text{ mm}$ (0.984 inch) ¹⁾ For type 321-W: $M = N + 25 \text{ mm}$ (0.984 inch) For type 331-W: $M = L + K + 25 \text{ mm}$ (0.984 inch) ¹⁾
Outer diameter	3 mm, 6 mm ²⁾
Version	Open connection wires; Single or double sensor
Mineral-insulated cable	Bendable and vibration-resistant ABB mineral insulated cable. Sheath material for resistance thermometers made from stainless steel 1.4571 / 316Ti or highly heat-resistant steel 2.4816 / Inconel 600 for thermocouples.-

1) With Energy Harvester: $K = 241 \text{ mm}$ (9.488 inches)

2) Not with Energy Harvester

3) The dimensions K, L, N and U are described on the following pages (thermowells, extension tubes)

Response times

The thermowell used in each application and the thermal contact between the thermowell and measuring inset have an impact on the response times of TSP temperature sensors. In the case of TSP321-W and TSP331-W temperature sensors, the design of the thermowell tip has been adapted to the measuring inset.

This maximizes heat transmission. The following table shows typical response times for the TSP321-W and TSP331-W sensors, measured in accordance with IEC 60751 in water at 0.4 m/s and a temperature rise from 25 °C (77 °F) to 35 °C (95 °F).

Sensor element	Exterior Ø [mm]	$t_{0.5}$ [s]	$t_{0.9}$ [s]
Single Pt100 / 4 L resistance thermometer--	6	4	10
Double type K thermocouple-	3	0.8	2.1

SensyTemp TSP300-W WirelessHART Temperature sensor with Energy Harvester

Sensor element – resistance thermometers

Specifications and designs					Single Pt100						Double Pt100			
Measuring insets with resistance thermometers					2-W.		3-W.		4-W.		2-W.		3-W.	
Sensor	Maximum vibration sensitivity	TSL	nBL	Class	Ø 3	Ø 6	Ø 3	Ø 6	Ø 3	Ø 6	Ø 3	Ø 6	Ø 3	Ø 6
TF	100 m/sec ² (10 g)	7 (0.276)	30 (1.181)	B	•	•	•	•	•	•		•		•
				A			•	•	•	•				•
				AA				•		•				
WW	30 m/sec ² (3 g)	50 (1.968)	60 (2.362)	B	•	•	•	•	•	•	•	•	•	•
				A			•	•	•	•				
				B	•	•	•	•	•	•	•	•	•	•
	100 m/sec ² (10 g)			A			•	•	•	•				

TSL = temperature-sensitive length in mm (inch)
 nBL = non-bendable length in mm (inch)
 Ø 3 / Ø 6 = measuring inset diameter in mm (inch)

TF = thin film resistor
 WW = wire wound resistor
 2-W / 3-W / 4-W = two-, three-, or four-wire circuit

Accuracy classes in accordance with IEC 60751

Resistance thermometer		Class	Measuring range	Calculation of the measuring error
In accordance with IEC 60751	Thin film resistor (TF)	B	-50 ... 400 °C (-58 ... 752 °F)	$\Delta t = \pm (0.30 + 0.0050 t)$
		A	-30 ... 300 °C (-22 ... 572 °F)	$\Delta t = \pm (0.15 + 0.0020 t)$
		AA	0 ... 100 °C (32 ... 212 °F)	$\Delta t = \pm (0.10 + 0.0017 t)$
	Wire wound resistor (WW)	B	-196 ... 600 °C (-320.8 ... 1112 °F)	$\Delta t = \pm (0.30 + 0.0050 t)$
		A	-196 ... 500 °C (-320.8 ... 932 °F)	$\Delta t = \pm (0.15 + 0.0020 t)$

|t| = insert required temperature value as an amount

Thermocouples

Specifications and designs					Single thermocouple						Double thermocouple					
Measuring insets with thermocouples					K		J		N		K		J		N	
Standard	Maximum vibration sensitivity	TSL	nBL	Class	Ø 3	Ø 6	Ø 3	Ø 6	Ø 3	Ø 6	Ø 3	Ø 6	Ø 3	Ø 6	Ø 3	Ø 6
IEC 60584	600 m/sec ² (60 g)	7 (0.276)	30 (1.181)	2	•	•	•	•		•	•	•	•	•		•
				1	•	•	•	•		•	•	•	•	•		•
ANSI MC 96.1				Standard	•	•	•	•		•	•	•	•	•		•
				Special	•	•	•	•		•	•	•	•	•		•

TSL = temperature-sensitive length in mm (inch)
 nBL = non-bendable length in mm (inch)

Ø 3 (0.118) / Ø 6 (0.236) = measuring inset diameter in mm (inch)

Accuracy classes in accordance with IEC 60584 and ANSI MC 96.1



Thermocouple		Class	Measuring range	Calculation of the measuring error
In accordance with IEC 60584	Type K (NiCr-Ni)	2	-40 ... 333 °C (-40 ... 631.4 °F)	± 2.5 °C (77 °F)
			333 ... 1200 °C (-631.4 ... 2192 °F)	± 0.0075 x t
		1	-40 ... 375 °C (-40 ... 707 °F)	± 1.5 °C
			375 ... 1000 °C (-707 ... 1832 °F)	± 0.0040 x t
	Type J (Fe-CuNi)	2	-40 ... 333 °C (-40 ... 631.4 °F)	± 2.5 °C
			333 ... 700 °C (-631.4 ... 1292 °F)	± 0.0075 x t
		1	-40 ... 375 °C (-40 ... 707 °F)	± 1.5 °C
			375 ... 750 °C (-707 ... 1382 °F)	± 0.0040 x t
	Type N (NiCrSi-NiSi)	2	-40 ... 333 °C (-40 ... 631.4 °F)	± 2.5 °C
			333 ... 1200 °C (631.4 ... 2192 °F)	± 0.0075 x t
		1	-40 ... 375 °C (-40 ... 707 °F)	± 1.5 °C
			375 ... 1200 °C (-707 ... 2192 °F)	± 0.0040 x t
Type E (NiCr-CuNi)	2	-40 ... 333 °C (-40 ... 631.4 °F)	± 2.5 °C	
		333 ... 900 °C (631.4 ... 1652 °F)	± 0.0075 x t	
	1	-40 ... 375 °C (-40 ... 707 °F)	± 1.5 °C	
		375 ... 800 °C (-707 ... 1472 °F)	± 0.0040 x t	
In accordance with ANSI MC 96.1	Type K (NiCr-Ni)	Standard	0 ... 293 °C (32 ... 559.4 °F)	± 2.2 °C
			293 ... 1250 °C (559.4 ... 2282 °F)	± 0.0075 x t
		Special	0 ... 275 °C (32 ... 527 °F)	± 1.1 °C
			275 ... 1250 °C (527 ... 2282 °F)	± 0.0040 x t
	Type J (Fe-CuNi)	Standard	0 ... 293 °C (32 ... 559.4 °F)	± 2.2 °C
			293 ... 750 °C (559.4 ... 1382 °F)	± 0.0075 x t
		Special	0 ... 275 °C (32 ... 527 °F)	± 1.1 °C
			275 ... 750 °C (527 ... 1382 °F)	± 0.0040 x t
	Type N (NiCrSi-NiSi)	Standard	0 ... 293 °C (32 ... 559.4 °F)	± 2.2 °C
			293 ... 1250 °C (559.4 ... 2282 °F)	± 0.0075 x t
		Special	0 ... 275 °C (32 ... 527 °F)	± 1.1 °C
			275 ... 1250 °C (527 ... 2282 °F)	± 0.0040 x t
Type E (NiCr-CuNi)	Standard	0 ... 293 °C (32 ... 559.4 °F)	± 2.2 °C	
		293 ... 900 °C (559.4 ... 1652 °F)	± 0.0075 x t	
	Special	0 ... 275 °C (32 ... 527 °F)	± 1.1 °C	
		275 ... 800 °C (527 ... 1472 °F)	± 0.0040 x t	

|t| = insert required temperature value as a value

SensyTemp TSP300-W WirelessHART Temperature sensor with Energy Harvester

Thermowells

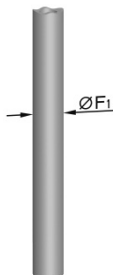
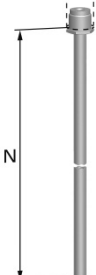
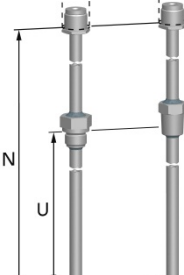
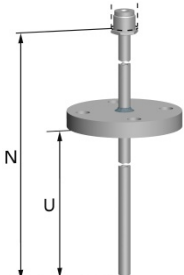
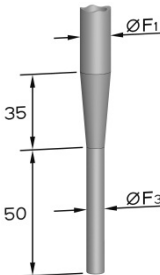
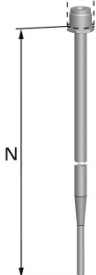
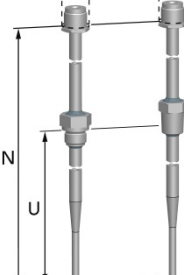
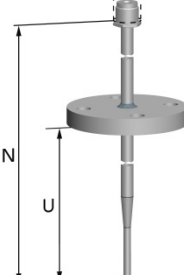
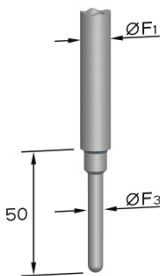
Type TSP321-W tubular thermowells

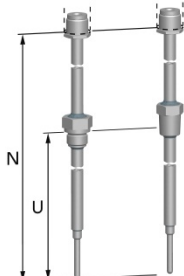
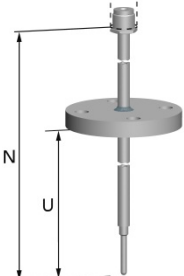
Straight shaft	DIN 43772 – form 2		DIN 43772 – form 2G		DIN 43772 – form 2F	
Head connection	M24 x 1.5					
						
1.4404/316L; 1.4571/316Ti	F1 = 12 mm	F1 = 14 mm	F1 = 12 mm	F1 = 14 mm	F1 = 12 mm	F1 = 14 mm
2.4819/C-276	–		F1 = 13.7 mm		F1 = 13.7 mm	
Measuring inset	Ø 6 mm	Ø 6 mm, tip 8	Ø 6 mm	Ø 6 mm, tip 8	Ø 6 mm	Ø 6 mm, tip 8
Tapered tip	DIN 43772 – form 3		DIN 43772 – form 3G		DIN 43772 – form 3F	
Head connection	M24 x 1.5					
						
1.4404/316L; 1.4571/316Ti	F1/F3 = 12/9 mm		F1/F3 = 12/9 mm		F1/F3 = 12/9 mm	
Measuring inset	Ø 6 mm		Ø 6 mm		Ø 6 mm	
Stepped tip	ABB – form 2S		ABB – form 2GS		ABB – form 2FS	
Head connection	M24 x 1.5					
						
1.4404/316L; 1.4571/316Ti	F1/F3 = 12/6 mm	F1/F3 = 14/6 mm	F2/F3 = 12/6 mm	F1/F3 = 14/6 mm	F1/F3 = 12/6 mm	F1/F3 = 14/6 mm
2.4819/C-276	–		F1/F3 = 13.7/6 mm ¹⁾		F1/F3 = 13.7/6 mm ²⁾	
Measuring inset	Ø 3 mm		Ø 3 mm		Ø 3 mm	

1) Only with thread G1/2A, 1/2" NPT

2) Flange 1.4571/316Ti, flange disc 2.4819/C-276

Type TSP331-W drilled thermowells

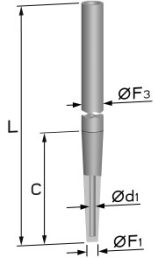
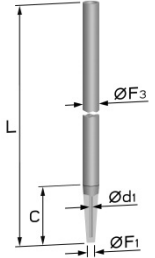
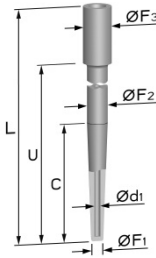
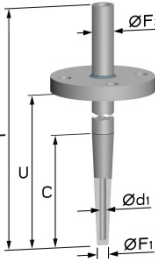
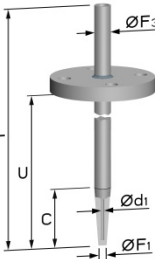
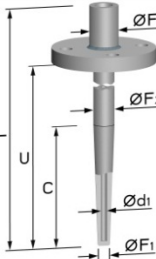
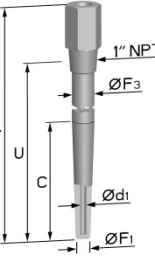
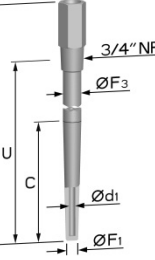
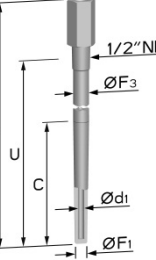
Weld-in thermowell		DIN 43772 – form 4		DIN 43772 – form 4		ABB – form PW	
Extension tube connection		M18 x 1.5		M14 x 1.5		1/2" NPT	
							
Material		1.4404/316L; 1.4571/316Ti; 1.7335/13CrMo4-5; 1.5415/15Mo3				1.4404/316L; 1.4571/316Ti 1.4876/Incoloy 800; 2.4360/Monel 400 2.4816/Inconel 600; 2.4819/C-276	
F3/F2/F1	d1	24h7/12.5 mm	7 mm	18h7/9 mm	3.5 mm	32/23/13.5 mm	7 mm
Measuring inset		Ø 6 mm		Ø 3 mm		Ø 6 mm	
Flange thermowell		DIN 43772 – form 4F		DIN 43772 – form 4F		ABB – form PF	
Extension tube connection		M18 x 1.5		M14 x 1.5		1/2" NPT	
							
Material		1.4404/316L; 1.4571/316Ti		1.4404/316L; 1.4571/316Ti		1.4404/316L; 1.4571/316Ti 1.4876/Incoloy 800; 2.4360/Monel 400 ¹⁾ 2.4816/Inconel 600; 2.4819/C-276 ¹⁾	
F3/F2/F1	d1	24/12.5 mm	7 mm	18/9 mm	3.5 mm	32/23/13.5 mm	7 mm
Measuring inset		Ø 6 mm		Ø 3 mm		Ø 6 mm	
Screw-in thermowell		ABB – form PS		ABB – form PS		ABB – form PS	
Extension tube connection		1/2" NPT; WAF 36		1/2" NPT; WAF 27		1/2" NPT; WAF 27	
							
Material		1.4404/316L; 1.4571/316Ti; 1.4876/Incoloy 800; 2.4360/Monel 400; 2.4816/Inconel 600; 2.4819/C-276					
F3/F1	d1	25/16 mm	7 mm	20/13.5 mm	7 mm	17/13.5 mm	7 mm
Measuring inset		Ø 6 mm		Ø 6 mm		Ø 6 mm	

1) 1.4876/Incoloy 800; 2.4360/Monel 400; 2.4816/Inconel 600; 2.4819/C-276 with flange in 1.4571/316Ti and flange disc

SensyTemp TSP300-W WirelessHART Temperature sensor with Energy Harvester

Standard lengths

Welded thermowells mm (inch)		
Form	N = 230 (9.055)	U = 100 (3.94)
2; 2G; 2F,	N = 290 (11.42)	U = 160 (6.30)
3; 3G; 3F;	N = 380 (14.96)	U = 250 (9.84)
2S; 2GS; 2FS	N = 530 (20.87)	U = 400 (15.75)
Drilled thermowells mm (inch)		
Form 4	L = 140 (5.51)	C = 65 (2.56)
	L = 200 (7.87)	C = 65 (2.56)
	L = 200 (7.87)	C = 125 (4.92)
	L = 260 (10.24)	C = 125 (4.92)
	L = 410 (16.14)	C = 275 (10.83)
Form 4S	L = 110 (4.33)	C = 65 (2.65)
	L = 140 (5.51)	C = 65 (2.65)
Form PW; PF; PS	U = 100 (3.94), 150 (5.91), 200 (7.87), 250 (9.84), 300 (11.81), 350 (13.78)	L = U + 65 (2.56)
Form 4F	U = 130 (5.12), L = 200 (7.87)	C = 65 (2.56)
	U = 190 (7.48), L = 260 (10.24)	C = 125 (4.92)
	U = 340 (13.39), L = 410 (16.14)	C = 275 (10.83)
Form 4FS	U = 130 (5.12), L = 200 (7.87)	C = 65 (2.65)

Special installation conditions for thermowells

For aggressive media, a flange thermowell made from stainless steel can be provided with an effective coating, for example ECTFE 0.5 mm.--

For highly corrosive measuring media, additional protection can also be provided in the form of a tantalum coating for flange thermowells Form 2F or 3F, outside diameter 12 mm, material 1.4571/316Ti or 1.4404/316L.

If required, contact your ABB partner.

Process connections

For tubular and drilled thermowells

Version	Sliding connection	
TSP321-W, plug-in thermowells, welded	G1/2"A, 1/2" NPT	
DIN 43772 – form 2, straight shaft		
DIN 43772 – form 3, tapered tip		
ABB – form 2S, stepped tip		
Version	Fixed connection	
TSP321-W, screw-in thermowells, welded	G1/2"A, G3/4"A, G1"A, 1/2" NPT, 3/4" NPT, 1" NPT	
DIN 43772 – form 2G, straight shaft	M20 x 1.5, M27 x 1.5	
DIN 43772 – form 3G, tapered tip		
ABB – form 2GS, stepped tip		
TSP331-W, screw-in thermowells, drilled	1/2" NPT, 3/4" NPT, 1" NPT	
ABB – form PS		
Version	Flange in accordance with EN 1092-1	Flange in accordance with ASME B16.5 TW
TSP321-W, flange thermowells, welded	Form B1 sealing surface,	Form RF sealing surface,
DIN 43772 – form 2F, straight shaft	Form C or D optional	Form RTJ optional
DIN 43772 – form 3F, tapered tip	DN 15, DN 20, DN 25, DN 40, DN 50	Nominal diameter 1", 1 1/2", 2"
ABB – form 2FS, stepped tip	Each PN 10 ... PN 40	Nominal pressure 150 #, 300 #, 600 #
TSP331-W, flange thermowells, drilled		
DIN 43772 – form 4F, F3 = 24 mm and 18 mm		
ABB – form PF		

Extension tubes for types TSP311, TSP331

The extension tube is the component between thermowell and connection head. It is used to bridge any existing insulation or serves as a cooling section between the temperature-sensitive electronics in the connection head and the actual process. Extension tubes for thermometers without a harvester have a standard length K of 150 mm (5.906 inch). For extension tubes with an Energy Harvester, the extension tube length K = 241 mm (9.488 inch).

Extension tube spacer

Extension tube spacers (maximum 4 spacers, 25 mm in length) enable the device to be used at higher process temperatures. The spacers reduce the overtemperature of the connection head and the temperature at the micro TEG (see also the specifications for the Energy Harvester).

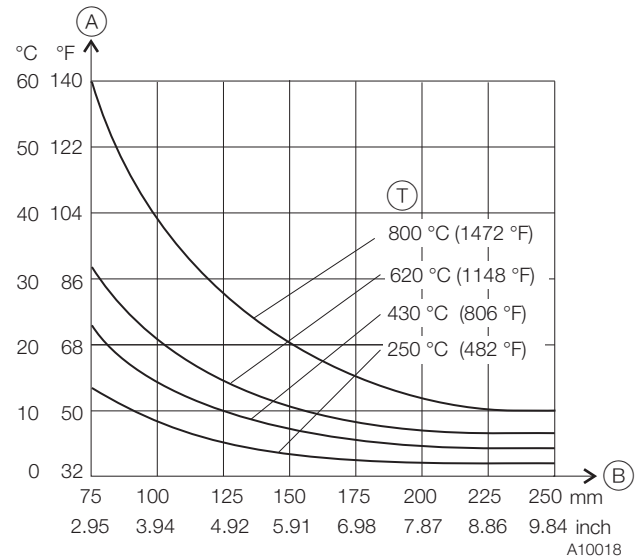
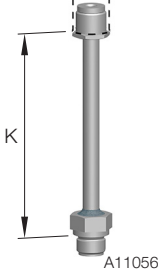
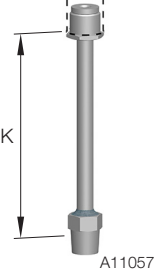
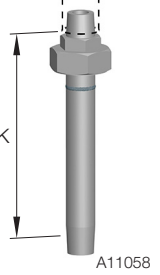
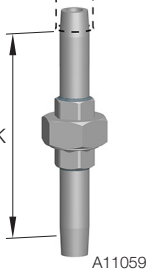
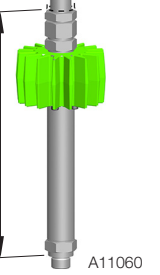

Fig. 7
 (A) Overtemperature at the connection head compared to the ambient temperature (B) Extension tube length (T) Flange temperature

Specifications

	Cylindrical screw-in thread	Conical screw-in thread	1/2" NPT – 1/2" NPT, separable (nipple-union)	1/2" NPT – 1/2" NPT, separable (nipple-union-nipple)	Energy Harvester
Head connection	M24 x 1.5		1/2" NPT		M24 x 1.5
					
Thermowell connection	M14 x 1.5; M18 x 1.5; M20 x 1.5; G1/2	1/2" NPT			1/2" NPT; M18 x 1.5
Material	1.4571/316Ti				1.4404/316L 1.4571/316Ti

SensyTemp TSP300-W WirelessHART Temperature sensor with Energy Harvester

Surface sensors

TSP341-W type design

Sensor mounting 90° to the piping

Design for simple surface mounting. A retaining board is mounted on the process side of the extension tube. The SensyTemp TSP341-W can be fastened to the surface using two tension clips.

With Energy Harvester

Adapters for fastening between the extension tube and retaining board can be selected to enable the Energy Harvester to be used at high surface temperatures. Minimum temperature difference of +35 K between the temperature at the process pipe and the environment.

Specifications

Thermal insulation of the sensor at the tube surface is mandatory.
Stainless steel clamp collars for DN 150 ... DN 500 (6 ... 20 inch)
Measuring range: -196 ... 600 °C (-320 ... 1112 °F)
Restricted temperature range if the Energy Harvester is used (see also the Energy Harvester specifications).
Sensor elements: see Built-in temperature sensors

Sensor mounting alongside the piping

Design for surface mounting with adjustable and vibration-resistant fastening. A retaining board is welded to the surface of the pipe or tank conveying the medium. The attachment is screwed on using a 60° angle plate fixed to the thermometer. This tilts the temperature sensor by 30°. The tip of the measuring inset with the sensor is fastened to the process pipe using two clamp collars.

Specifications

Thermal insulation of the sensor at the tube surface is mandatory.
Stainless steel clamp collars for DN 150 ... DN 500 (6 ... 20 inch)
Measuring range: -196 ... 600 °C (-320 ... 1112 °F)
Restricted temperature range if the Energy Harvester is used (see also the Energy Harvester specifications).
Sensor elements: see Built-in temperature sensors
Measuring inset length M: 400 mm (15.748 inch)
Retaining board material: 1.4571/316Ti, 1.4404/316L or process-specific material

Dimensions mm (inch)

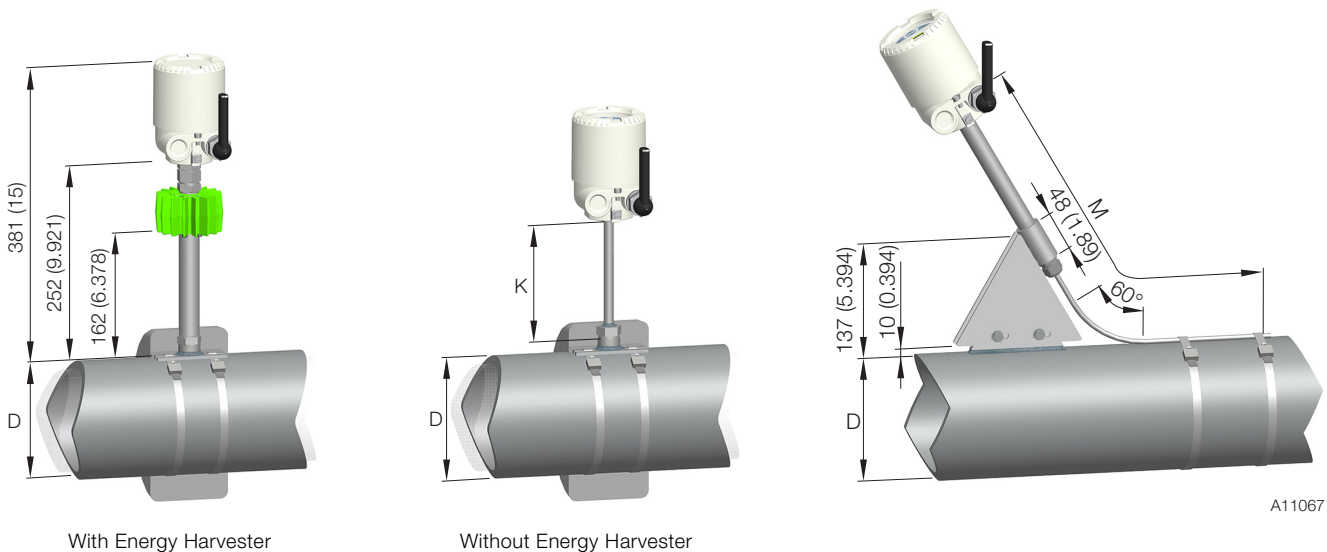

A11067

Fig. 8: Sensor fastening 90° to piping / alongside piping

Connection head

The connection head holds and protects the measurement and sender electronics and the battery required for these electronics. An LCD display can be installed as an option. The antenna and head can be rotated. This enables optimum transmission characteristics to be set.

Specifications

- Ambient temperature -40 ... 85 °C (-40 ... 185 °F)
- Optional -50 ... 85 °C (-58 ... 185 °F)
(restricted range during operation with LCD display or with explosion-proof design)

Electrical connections

- Spring cage terminals
- Connection leads up to max. 1.5 mm² (AWG 16)

Material

- Aluminum, epoxy-coated
- Stainless steel

Color

- Gray RAL 9002

IP rating

- IP66 / IP67

Dimensions mm (inch)

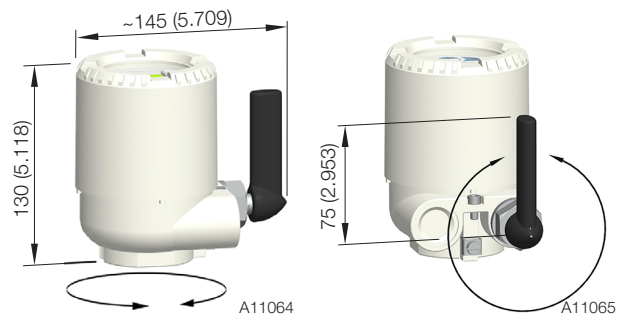

Electrical connections

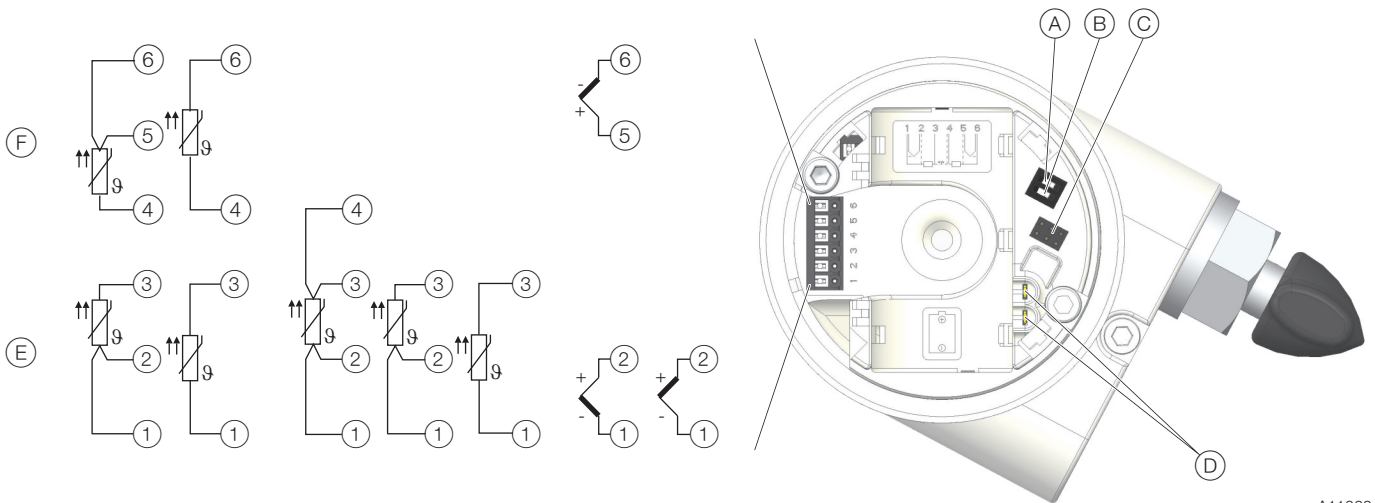

Fig. 9: Electrical connections (opened connection head)

(1)–(6) sensor connections (from measuring inset) (A) DIP switch, hardware write protection (B) DIP switch, standby mode (C) LCD display connection (D) HART maintenance port (hand-held terminal) (E) Sensor 1 (F) Sensor 2

SensyTemp TSP300-W WirelessHART

Temperature sensor with Energy Harvester

Transmitter

Specifications

Electromagnetic compatibility

Interference immunity in accordance with IEC/EN 61326-1 (industrial environment, influence < 1%)

Vibration resistance in accordance with IEC 60068-2-6: 10 ... 60 Hz 0.21 mm / 60 ... 2000 Hz 3g

Humidity in accordance with IEC 60068-2-30, 95%

With integrated adjustable omnidirectional antenna
Range: up to 300 m (328 yds)

Wireless refresh rate

- Standard 16 seconds
- Configurable between 4 seconds and 60 minutes

Transmission protocol: WirelessHART Version 7 (IEEE 802.15.4-2006)

Frequency band: 2.4 GHz (ISM-band, license-free)
Transmission power: max. 10 mW (10 dBm) EIRP

Minimum distance between antenna and persons: 0.2 m (8 inch)

User-defined configuration of network ID, join key via LCD display with button operation or via EDD or DTM.

Resistance thermometer input

Resistance thermometer

- Pt100 in accordance with IEC 60751

Sensor connection type

- Two-, three-, four-wire circuit

Connection lead

- Maximum sensor lead resistance of 50 Ω per line in accordance with NE 89
- Three-wire circuit:

Symmetrical sensor line resistances

- Two-wire circuit:

Compensation up to 100 Ω total lead resistance

Measurement current < 300 μ A

Sensor short circuit < 5 Ω (for resistance thermometers)

Sensor wire break

- Measuring range: 0 ... 500 Ω > 0.6 ... 10 k Ω

Corrosion detection in accordance with NE 89

- Three-wire resistance measurement > 50 Ω
- Four-wire resistance measurement > 50 Ω

Sensor error signaling

- Resistance thermometers: short-circuit and wire break

Thermocouple input

Types K, J, N, E in accordance with IEC 60584, ANSI MC 96.1

Connection lead

- Maximum sensor line resistance 1.5 k Ω per lead

Sensor wire break monitoring in accordance with NE 89

- Pulsed with 1 μ A outside measurement interval
- Thermocouple measurement 5.3 ... 10 k Ω

Input resistance > 10 M Ω

Internal reference junction Pt1000, IEC 60751 Class B

Sensor error signaling

- Thermocouple: wire break

Free style characteristic curve / 32-point -sampling point table

- Resistance measurement up to max. 5 k Ω
- Voltages up to max. 1.1 V

Sensor error adjustment

- Via Callendar-Van Dusen coefficients
- Via value table of 32 reference points
- Via single-point adjustment (offset adjustment)
- Via two-point adjustment

Input functionality

- 1 sensor
- 2 sensors:
 - mean measurement,
 - differential measurement,
 - sensor redundancy,
 - Sensor drift monitoring

Measuring accuracy

Includes linearity error, repeatability / hysteresis at 23 °C (73.4 °F) ± 5 K ambient temperature.
Information on measuring accuracy corresponds to 3 σ (Gaussian distribution).

Sensor element	Measuring range limits	Minimum span	Digital measuring accuracy (24 bit A/D conversion)
Resistance thermometer			
Pt100 (α=0.003850)	-196 ... 600 °C (-320 ... 1112 °F)	10 °C (18 °F)	± 0.08 °C (± 0.14 °F)
Thermocouples			
Type K (Ni10Cr-Ni5)	-270 ... 1372 °C (-454 ... 2502 °F)	50 °C (90 °F)	± 0.35 °C (± 0.63 °F)
Type J (Fe-Cu45Ni)	-210 ... 1200 °C (-346 ... 2192 °F)		
Type N (Ni14CrSi-NiSi)	-270 ... 1300 °C (-454 ... 2372 °F)		
Type E (Ni10Cr-Cu45Ni)	-270 ... 1000 °C (-454 ... 1832 °F)		

Operating influence

Sensor element	Ambient temperature effect ¹⁾
Pt100 (all connection types)	± 0.004 °C (± 0.007 °F)
Thermocouple (all defined types)	± [(0.001 % x (ME[mV] / MS[mV]) + (100 % x (0.009 °C / MS [°C]))] ^{2) 3)}

1) Per 1 °C (1.8 °F) deviation to 23 °C (73.4 °F) based on the digital measured value

2) The percentages refer to the configured measuring span

3) ME = voltage value of the sensor at upper range value in accordance with the standard

MA = voltage value of the sensor at lower range value in accordance with the standard

MS = voltage value of the thermocouple over the measuring span in accordance with the standard. MS = (ME - MA)

LCD display

In the connection head

For displaying measurement and status information

For on-site configuration

Automatic shutdown after 1 minute without activating the

buttons (can be configured)

Manual reactivation via push buttons



Fig. 10: LCD display

SensyTemp TSP300-W WirelessHART

Temperature sensor with Energy Harvester

Communication

Configuration parameters

- Sensor type, connection type
- Error signaling
- Measuring range
- General data, e.g. TAG number
- Damping
- Warning and alarm limits
- Output signal simulation
- Burst rate
- Burst commands
- Network ID
- Join key
- Software write protection

Diagnostic information in accordance with NE 107

Standard:

- Sensor error signaling
(wire break or short circuit)
- Device error
- Over / under alarm limits
- Over / under measuring range
- Simulation active

Advanced:

- Sensor redundancy / sensor backup active
(sensor failure)
- Drift monitoring
- Sensor / sensor lead corrosion
- Drag indicator for sensor 1, sensor 2 and ambient
temperature
- Over ambient temperature
- Under ambient temperature
- Operating hours counter
- Radio interface error
- Join status
- Battery status

WirelessHART

The device is listed with the FieldComm Group.

Manufacturer ID	0x1A
Device ID	0x9B
Profile	HART 7.5
Network ID	0xABB (2747 dec.)
Join key	0x57495245 0x4c455353 0x4649454c 0x444b4559
Configuration	On device using LCD indicator DTM EDD

0x = hexadecimal

NOTE

For security reasons it is strongly recommended, to change network ID and join key during commissioning.

Power supply

Energy Harvester

Specifications

The Energy Harvester is based on the thermoelectrical effect (Seebeck effect) and requires a temperature difference of 35 K between the process pipe surface and the ambient temperature in order to provide all the energy required for the transmitter and sender electronics.

However, an integrated power management system provides energy if the temperature difference is less than 35 K. Only the remaining energy needed is taken from the integrated battery, thereby increasing its availability. The energy withdrawal is provided as a percentage value.

Operating temperature at the process connection

- 40 ... 150 °C (-40 ... 302 °F)

Adapters for fastening between the extension tube and thermowell can be selected to enable the Energy Harvester to be used at high process temperatures.

Threaded connection to the process

- M18 x 1.5 or 1/2" NPT

Material

- 1.4404/316L

Radio approvals

Telecommunications directive

Every wireless measuring device must be certified in accordance with the telecommunications directive, in this case the frequency range. This certification is country-specific.

European directives

Radio Equipment Directive 2014/53/EU

Within Europe, use of the 2400 - 2483.5 MHz frequency band is not harmonized. Country-specific regulations must therefore be observed.

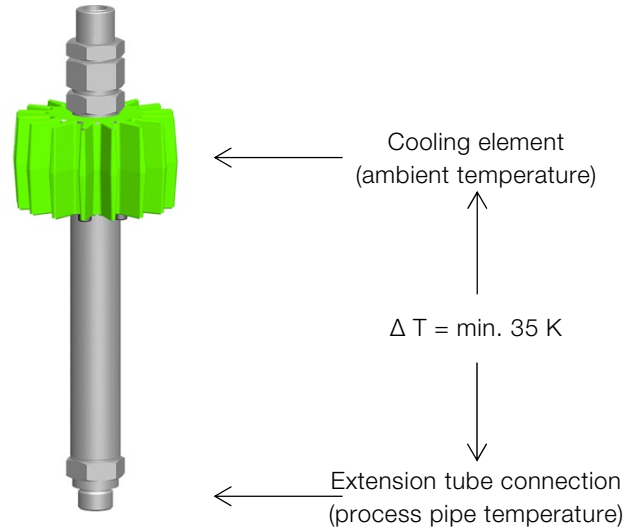

Battery

Standard lithium battery

Service life 5 years (without Energy Harvester) under the following

reference conditions:

25 °C (77 °F) ambient temperature

Refresh rate 16 s

3 additional network participants

LCD off

Restrictions for Norway

Operation not permitted within a radius of 20 km around Ny-Alesund in Svalbard. For more information, see www.npt.no Norway Posts and Telecommunications site

USA / Canadian directives

FCC Part 15.247:2009 (USA)

IC RSS-210 and ICES-003 (Canada)

SensyTemp TSP300-W WirelessHART Temperature sensor with Energy Harvester

Use in potentially explosive atmospheres according to ATEX and IECEx

i NOTICE

- Further information on the approval of devices for use in potentially explosive atmospheres can be found in the explosion protection test certificates (at www.abb.com/temperature).
- Depending on the design, a specific marking in accordance with ATEX or IECEx applies.

Ex-marking Transmitter

Model TSP3x1-W-A6..., TSP3x1-W-H6...
(Sensor with transmitter in zone 0, 1, or 2))

ATEX	IECEx
II 1 G Ex ia IIC T4...T1 Ga	Ex ia IIC T4...T1 Ga
Certificate no.: PTB 14 ATEX 2010X	Certificate no.: In preparation
<ul style="list-style-type: none"> – The transmitter and the connected temperature sensor may be used complete in zone 0, zone 1 or zone 2 – The temperature range corresponds to the information in chapter "Temperature data" on page 20 	

The device is supplied with or without an LCD indicator (order option "Housing / Indicators").
The LCD indicator has been awarded the following certificates:

ATEX	IECEx
Certificate no.: PTB 05 ATEX 2079X	Certificate no.: IECEx PTB 12.0028X

Temperature data

For all TSP3x1-W versions there are two relevant parts of the Sensor with different temperature ranges:

1. At the enclosure of the transmitter the temperatures must be in the range of -40 °C up to 70 °C (-40 ... 158 °F).
2. The process temperature at the measuring point could be different, but the influence of the self-heating from the sensor, the temperature rise in the electronic and the temperature class/zone has to be taken into account.

Model TSP341-W-A6 / H6-Y22 and Y23

The TSP341-W xx Y22 and Y23 (...) can be used at ambient temperatures from -40°C up to 70 °C (-40 ... 158 °F) at the transmitter enclosure and the maximum process temperature for each temperature class and each individual setup has to be defined with respect to the maximum of 70 °C (158 °F) at the electronic and the self-heating of the sensor element above.

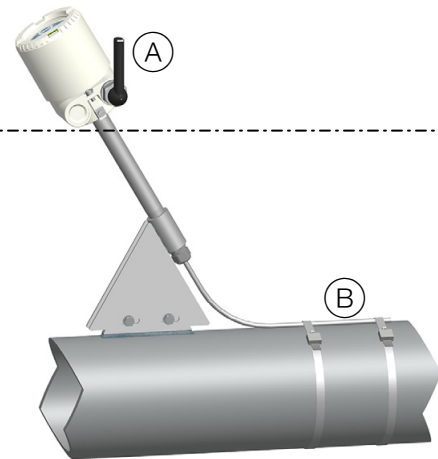

Fig. 11: Sensor mounting alongside the piping

A11111

Position	Temperature
(A)	T_{ambient} : -40 °C ... 70 °C (-40 ... 158 °F)
(B)	Surface temperature: Temperature class reduced by self-heating of the Sensor

TSP3x1-W (X=1-3) and TSP341-W-Y11 with Energy Harvester

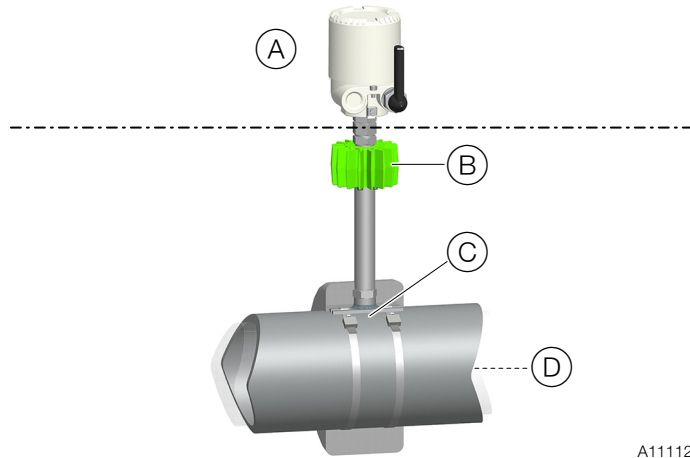
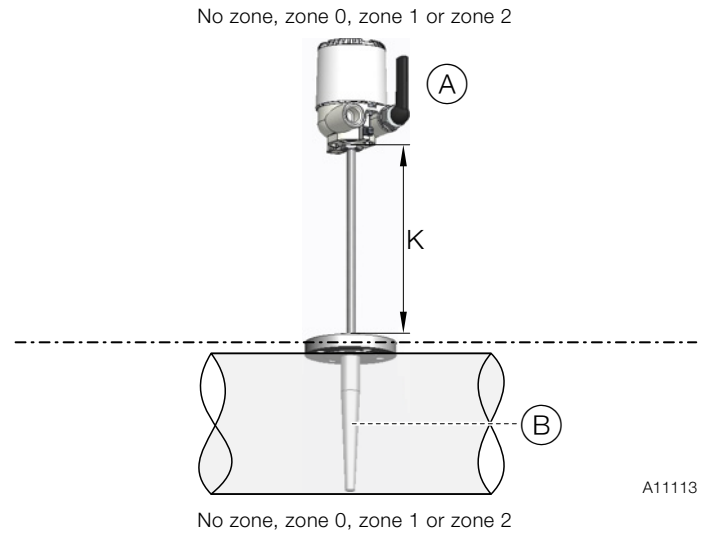

Fig. 12: Sensor mounting 90° to the piping with Energy Harvester

Position	Temperature
(A)	T_{ambient} : -40 °C ... 70 °C (-40 ... 158 °F)
(B)	<ul style="list-style-type: none"> – The Energy Harvester can be used in the temperature range of -40 ... 150 °C (-40 ... 302°F). – For intrinsic safety maximum temperature delta at the Energy Harvester of 150 K is allowed
(C)	TEG unit used: Maximum surface temperature 150 °C (302 °F)
(D)	T_{process} : -40 °C ... 150 °C (-40 ... 302°F)

A11112

TSP3x1-W (X=1-3) and TSP341-W-Y11 without Energy Harvester



**Fig. 13: Sensor with extension tube
K Extension tube length**

Position	Temperature
(A)	Temperature region for the electronic: -40 °C ... 70 °C (-40 ... 158 °F) Maximum T_{ambient} : 70 °C (158 °F) – heating due the process temperature
(B)	Maximum T_{process} : Temperature class reduced by selfheating of the sensor

A11113

For TSP3x1-W (X:1-3) and TSP 341-W-xx-Y11 without Energy Harvester the use for the different temperature classes depends on the process temperature and the zone definition. The transmitter enclosure must not be heating up higher than 70°C (158 °F).

Depending on the extension tube length "K" and the process temperature the enclosure for the transmitter will heat up so the ambient temperature has to be reduces for such cases.

SensyTemp TSP300-W WirelessHART Temperature sensor with Energy Harvester

The following table shows the T_{ambient} for TSP3x1-W at different process temperature. A protection against radiation heat has to be realized. (For example: isolation with 25mm thickness around the process enclosure.)

T_{process}	T_{ambient} for extension tube length K = 150 mm (5.9 in)	T_{ambient} for extension tube length K = 250 mm (9.8 in)
100 °C	max. 65 °C (149 °F)	max. 70 °C (158 °F)
200 °C	max. 60 °C (140 °F)	max. 70 °C (158 °F)
300 °C	max. 60 °C (140 °F)	max. 70 °C (158 °F)
400 °C	max. 55 °C (131 °F)	max. 65 °C (149 °F)

Self heating of the sensor

The self heating of the sensor is generally defined. The attached tables take these values into account and show the resulting maximum process temperature for the different temperature classes for each configuration of the TSP3x1-W

Ex-Zone	T4 135 °C (-5 K)	T3 200 °C (-5 K)	T2 (300 °C) (-10 K)	T1 400 °C (-10 K)
Zone 1	123 °C	188 °C	283 °C	383 °C
Zone 0	96 °C	148 °C	223 °C	303 °C

Zone 0 with consideration of EN1127-1.

Electrical data HART maintenance port

	HART maintenance port on TTF300-W	Maximum external connection values
Maximum voltage	$U_o = 5.4 \text{ V}$	$U_i = 2.6 \text{ V}$
Short-circuit current	$I_o = 25 \text{ mA}$	$I_i = 18 \text{ mA}$
Maximum power	$P_o = 34 \text{ mW}$	—
Inductance	$L_i = 0 \text{ mH}$	$L_o = 1 \text{ mH (IIC)}$
Capacitance	$C_i = 1.2 \text{ }\mu\text{F}$	$C_o = 0.4 \text{ }\mu\text{F (IIC)}$

Ordering Information

IMPORTANT (NOTE)

Order codes cannot be combined at will. Your ABB partner will be happy to answer any questions you might have regarding installation feasibility. All documentation, declarations of conformity, and certificates are available in ABB's download area.

Main ordering information SensyTemp TSP311-W

Base model	TSP311-W	XX	XX	XX	XX	XX	XX	XX	XX	XX	XX	
SensyTemp TSP311-W Temperature Sensor, without thermowell, WirelessHART												
Explosion Protection / Approvals				Continued see next page								
Without		Y0										
Intrinsic Safety: ATEX II 1 G Ex ia IIC T4		A6										
Intrinsic Safety: IECEx ia IIC T4		H6										
Extension Tube Length				Continued see next page								
Without Extension Tube		Y0										
K = 242 mm (9.5 in.), free length up to cooling element = 152 mm (6 in.), Harvester		H1										
K = 267 mm (10.5 in.), free length up to cooling element = 152 mm (6 in.), Harvester, adapter 25 mm (1 in.)		H2										
K = 292 mm (11.5 in.), free length up to cooling element = 152 mm (6 in.), Harvester, adapter 50 mm (2 in.)		H3										
K = 317 mm (12.5 in.), free length up to cooling element = 152 mm (6 in.), Harvester, adapter 75 mm (3 in.)		H4										
K = 342 mm (13.5 in.), free length up to cooling element = 152 mm (6 in.), Harvester, adapter 100 mm (4 in.)		H5										
K = 150 mm (6 in.)		K1										
Customer specific length < 150 mm (< 5.9 in.)		W1										
Customer specific length 150 ... < 300 mm (5.9 ... < 11.8 in.)		W2										
Customer specific length 300 ... < 400 mm (11.8 ... < 15.7 in.)		W4										
Customer specific length 400 ... < 500 mm (15.7 ... < 19.7 in.)		W5										
Customer specific length 500 ... < 600 mm (19.7 ... < 23.6 in.)		W6										
Customer specific length 600 ... < 750 mm (23.6 ... < 29.5 in.)		W7										
Customer specific length 750 ... < 1000 mm (29.5 ... < 39.4 in.)		W8										
Customer specific length 1000 ... < 1500 mm (39.4 ... < 59 in.)		Y1										
Customer specific length 1500 ... < 2000 mm (59 ... < 78.7 in.)		Y3										

SensyTemp TSP300-W WirelessHART Temperature sensor with Energy Harvester

Main ordering information SensyTemp TSP311-W	XX	XX	XX	XX	XX	XX	XX	XX
Thermowell Connection								
No extension / Connection head with thread M24 x 1,5	W1							
No extension / Connection head with thread 1/2 in. NPT	W2							
No extension / Connection head with lock nut M24 x 1.5	W3							
Double nipple / G 1/2 A / G 1/2 A	W4							
Double nipple / 1/2 in. NPT / 1/2 in. NPT	W5							
Extension tube with Cylindrical thread G 1/2 A	G1							
Extension tube with Cylindrical thread G 3/4 A	G2							
Extension tube with Cylindrical thread M14 x 1,5	M1							
Extension tube with Cylindrical thread M18 x 1,5	M2							
Extension tube with Cylindrical thread M20 x 1,5	M3							
Extension tube with Cylindrical thread M24 x 1,5	M4							
Extension tube with Cylindrical thread M27 x 2	M5							
Extension tube with conical thread 1/2 in. NPT	N1							
Extension with Male nut, thread G 1/2 in.	U6							
Extension tube with adjustable compression fitting G 1/2 A	A1							
Extension tube with adjustable compression fitting 1/2 in. NPT	A2							
Nipple / 1/2 in. NPT / 1/2 in. NPT	N2							
Nipple-Union / 1/2 in. NPT / Union 1/2 in. NPT	N3							
Nipple - Union - Nipple / 1/2 in. NPT / 1/2 in. NPT	N4							
Others	Z9							
Immersion Length								
U = 140 mm (5.6 in.)	U2							
U = 200 mm (8 in.)	U4							
U = 260 mm (10.3 in.)	U6							
Customer specific length < 150 mm (< 5.9 in.)	W1							
Customer specific length 150 ... < 300 mm (5.9 ... < 11.8 in.)	W2							
Customer specific length 300 ... < 400 mm (11.8 ... < 15.7 in.)	W4							
Customer specific length 400 ... < 500 mm (15.7 ... < 19.7 in.)	W5							
Customer specific length 500 ... < 600 mm (19.7 ... < 23.6 in.)	W6							
Customer specific length 600 ... < 750 mm (23.6 ... < 29.5 in.)	W7							
Customer specific length 750 ... < 1000 mm (29.5 ... < 39.4 in.)	W8							
Customer specific length 1000 ... < 1500 mm (39.4 ... < 59 in.)	Y1							
Customer specific length 1500 ... < 2000 mm (59 ... < 78.7 in.)	Y3							
Customer specific length 2000 ... < 3000 mm (78.7 ... < 118 in.)	Y5							
Customer specific length 3000 ... < 5000 mm (118 ... < 196.8 in.)	Y7							
Customer specific length 5000 ... < 10000 mm (196.8 ... < 393.7 in.)	Z1							
Customer specific length 10000 ... < 15000 mm (393.7 ... < 590.5 in.)	Z3							
Customer specific length 15000 ... < 20000 mm (590.5 ... < 787.4 in.)	Z4							

Main ordering information SensyTemp TSP311-W	XX	XX	XX	XX	XX	XX
Measuring Inset Type						
RTD, Basic application, TF, measuring range -50 ... 400 °C (-58 ... 752 °F), 10 g	S1					
RTD, Extended vibration resistance, TF, measuring range -50 ... 400 °C (-58 ... 752 °F), 60 g	S2					
RTD, Extended measuring range, WW, measuring range -196 ... 600 °C (-321 ... 1112 °F), 10 g	D1					
RTD, Extended measuring range, WW, measuring range -196 ... 600 °C (-321 ... 1112 °F), 3 g	D2					
Thermocouple	T1					
Others	Z9					
Measuring Inset Diameter						
3 mm (0,12 in.)						D3
6 mm (0,24 in.)						D6
Others						Z9
Sensor Type and Wiring						
1 x Pt100, 2-wire						P1
1 x Pt100, 3-wire						P2
1 x Pt100, 4-wire						P3
2 x Pt100, 2-wire						P4
2 x Pt100, 3-wire						P5
1 x Type K (NiCr-NiAl)						K1
2 x Type K (NiCr-NiAl)						K2
1 x Type J (Fe-CoNi)						J1
2 x Type J (Fe-CoNi)						J2
1 x Type N (NiCrSi-NiSi)						N1
2 x Type N (NiCrSi-NiSi)						N2
1 x Type T (Co-CoNi)						T1
2 x Type T (Co-CoNi)						T2
1 x Type E (NiCr-CoNi)						E1
2 x Type E (NiCr-CoNi)						E2
Sensor Accuracy						
RTD, Accuracy Class B, IEC 60751						B2
Thin Film, Accuracy Class A, IEC 60751, Range -30 ... 350 °C (-22 ... 662 °F)						S1
Wire Wound, Accuracy Class A, IEC 60751, Range -196 ... 500 °C (-321 ... 932 °F)						D1
Wire Wound, Double, Accuracy Class A, IEC 60751, Range 0 ... 250 °C (32 ... 482 °F)						D2
TC, Accuracy Class 2, IEC 60584						T2
TC, Accuracy Class 1, IEC 60584						T1
TF, Accuracy Class AA, IEC 60751, Range 0 ... 100 °C (0 ... 212 °F)						S3
TC, Standard Accuracy ANSI MC96.1						T4
TC, Special Accuracy ANSI MC96.1						T3
Others						Z9

SensyTemp TSP300-W WirelessHART Temperature sensor with Energy Harvester

Main ordering information SensyTemp TSP311-W		XX	XX
Connection Head Type / Material			
AGLH / Aluminium, high cover, screwed		L2	
AGLD / Aluminium, screwed cover with display		L4	
AGSH / Stainless steel, high cover, screwed		S2	
AGSD / Stainless steel, screwed cover with display		S4	
Others		Z9	
Transmitter			
WirelessHART			W1
WirelessHART + Harvester			W3

Additional ordering information SensyTemp TSP311-W

	XX	XX	XX	XX	XX	XX	XX
Declaration of Compliance: 2.1							
Declaration of compliance according EN 10204-2.1, with the order	C4						
Test report: 2.2, Batch Values							
Test report according EN 10204-2.2 for batch values, MIC-TC		C5					
Inspection Certificate: 3.1, Visual, Dimensional and Functional Test							
Inspection certificate according EN 10204-3.1, visual, dimensional and functional test			C6				
Inspection Certificate: 3.1, Sensor Tolerance							
Inspection certificate according EN 10204-3.1, sensor tolerance						CC	
Certificate: Sensor Calibration							
Inspection certificate according EN 10204-3.1, sensor calibration, single RTD							CD
Inspection certificate according EN 10204-3.1, sensor calibration, double RTD							CE
Inspection certificate according EN 10204-3.1, sensor calibration, single thermocouple							CF
Inspection certificate according EN 10204-3.1, sensor calibration, double thermocouple							CG
DAkkS sensor calibration, single RTD, calibration certificate per thermometer							CH
DAkkS sensor calibration, double RTD, calibration certificate per thermometer							CJ
DAkkS sensor calibration, single thermocouple, calibration certificate per thermometer							CK
DAkkS sensor calibration, double thermocouple, calibration certificate per thermometer							CL
Certificate: Other							
Other							CZ
Number of Calibration Test Points							
1 point							P1
2 points							P2
3 points							P3
4 points							P4
5 points							P5

Additional ordering information SensyTemp TSP311-W	XX	XX	XX
Temperatures for Sensor Calibration			
Standard calibration: 0 °C (32 °F)	V1		
Standard calibration: 100 °C (212 °F)	V2		
Standard calibration: 400 °C (752 °F)	V3		
Standard calibration: 0 °C and 100 °C (32 °F and 212 °F)	V4		
Standard calibration: 0 °C and 400 °C (32 °F and 752 °F)	V5		
Standard calibration: 0 °C, 100 °C and 200 °C (32 °F, 212 °F and 392 °F)	V7		
Standard calibration: 0 °C, 200 °C and 400 °C (32 °F, 392 °F and 752 °F)	V8		
Standard calibration: Customer specific temperatures	V6		
DAkkS calibration: 0 °C (32 °F)	D1		
DAkkS calibration: 100 °C (212 °F)	D2		
DAkkS calibration: 400 °C (752 °F)	D3		
DAkkS calibration: 0 °C and 100 °C (32 °F and 212 °F)	D4		
DAkkS calibration: 0 °C and 400 °C (32 °F and 752 °F)	D5		
DAkkS calibration: 0 °C, 100 °C and 200 °C (32 °F, 212 °F and 392 °F)	D7		
DAkkS calibration: 0 °C, 200 °C and 400 °C (32 °F, 392 °F and 752 °F)	D8		
DAkkS calibration: Customer specific temperatures	D6		
Documentation Language			
German		M1	
English		M5	
Name Plate			
Stainless steel plate with TAG no.			T1

SensyTemp TSP300-W WirelessHART Temperature sensor with Energy Harvester

Main ordering information SensyTemp TSP321-W

Base model	TSP321-W	XX	XX	XX	XX	XX	XX	XX	XX	XX	XX	XX	XX	XX
SensyTemp TSP321-W Temperature Sensor, with tubular thermowell, WirelessHART														
Explosion Protection / Approvals					Continued see next page									
Without		Y0												
Intrinsic Safety: ATEX II 1 G Ex ia IIC T4		A6												
Intrinsic Safety: IECEx ia IIC T4		H6												
Wetted Thermowell Material														
Stainless Steel ASTM 316L (1.4404)			S1											
Stainless Steel ASTM 316Ti (1.4571)			S2											
Heat Resistent Steel 1.4762			H2											
Stainless Steel AISI 314 (1.4841)			H3											
Stainless Steel ASTM 904L (1.4539)			S4											
Ni-Alloy Hastelloy C-276 (2.4819)			N1											
Ni-Alloy Hastelloy C-4 (2.4610)			N2											
Others			Z9											
Thermowell Type														
Tubular thermowell with straight shaft (DIN 43772, Form 2)			A1											
Flanged tubular thermowell with straight shaft (DIN 43772, Form 2F)			A2											
Screwed tubular thermowell with straight shaft (DIN 43772, Form 2G)			A3											
Tubular thermowell, stepped tip (ABB Form 2S)			B1											
Flanged tubular thermowell, stepped tip (ABB Form 2FS)			B2											
Screwed tubular thermowell, stepped tip (ABB Form 2GS)			B3											
Tubular thermowell, tapered (DIN 43772, Form 3)			C1											
Flanged tubular thermowell, tapered (DIN 43772, Form 3F)			C2											
Screwed tubular thermowell, tapered (DIN 43772, Form 3G)			C3											
Screwed tubular thermowell without extension, straight shaft (ABB Form 2G0)			A4											
Screwed tubular thermowell without extension, stepped tip (ABB Form 2GS0)			B4											
Tubular thermowell, stepped tip 9 mm (0.36 in.) (ABB Form 2S/9)			K1											
Flanged tubular thermowell, stepped tip 9 mm (0.36 in.) (ABB Form 2FS/9)			K2											
Screwed tubular thermowell, stepped tip 9 mm (0.36 in.) (ABB Form 2GS/9)			K3											

Main ordering information SensyTemp TSP321-W	XXX	XX	XX	XX	XX	XX	XX	XX	XX
Process Connection									
Without process connection (weld-in type)	Y00								
Adjustable compression fitting G 1/2, stainless steel	A01								
Adjustable compression fitting 1/2 in. NPT, stainless steel	A02								
Cylindrical thread G 1/2 A	S01								
Cylindrical thread G 3/4 A	S02								
Cylindrical thread G 1 A	S03								
Conical thread 1/2 in. NPT	S04								
Conical thread 3/4 in. NPT	S05								
Conical thread 1 in. NPT	S06								
Cylindrical thread M20 x 1.5	S07								
Cylindrical thread M27 x 2	S08								
Conical thread 1/2 in. BSPT	S09								
Conical thread 3/4 in. BSPT	S10								
Conical thread 1 in. BSPT	S11								
Flange DN 15 PN 10 ... PN 40, B1, EN 1092-1	F01								
Flange DN 20 PN 10 ... PN 40, B1, EN 1092-1	F02								
Flange DN 25 PN 10 ... PN 40, B1, EN 1092-1	F03								
Flange DN 40 PN 10 ... PN 40, B1, EN 1092-1	F04								
Flange DN 50 PN 10 ... PN 40, B1, EN 1092-1	F05								
Flange DN 50 PN 6, B1, EN 1092-1	F06								
Flange 1 in. 150 lbs, RF, ASME B16.5	F07								
Flange 1 in. 300 lbs, RF, ASME B16.5	F08								
Flange 1-1/2 in. 150 lbs, RF, ASME B16.5	F11								
Flange 1-1/2 in. 300 lbs, RF, ASME B16.5	F12								
Flange 1-1/2 in. 600 lbs, RF, ASME B16.5	F13								
Flange 1-1/2 in. 900 / 1500 lbs, RF, ASME B16.5	F14								
Flange 2 in. 150 lbs, RF, ASME B16.5	F15								
Flange 2 in. 300 lbs, RF, ASME B16.5	F16								
Flange 2 in. 600 lbs, RF, ASME B16.5	F17								
Flange 2 in. 900 / 1500 lbs, RF, ASME B16.5	F18								
Others	Z99								
Thermowell Diameter									
9 mm (0.36 in.)	A1								
11 mm (0.44 in.)	A2								
12 mm (0.48 in.)	A3								
14 mm (0.56 in.)	A4								
13.7 mm (0.54 in.)	B2								
10 mm (0.4 in.)	A6								
Others	Z9								

SensyTemp TSP300-W WirelessHART Temperature sensor with Energy Harvester

Main ordering information SensyTemp TSP321-W	XX	XX	XX	XX	XX	XX	XX
Immersion Length							
Without fixed immersion length	Y0						
U = 100 mm (4 in.)	U1						
U = 160 mm (6.3 in.)	U3						
U = 250 mm (10 in.)	U5						
U = 400 mm (16 in.)	U7						
Customer specific length < 150 mm (< 5.9 in.)	W1						
Customer specific length 150 ... < 300 mm (5.9 ... < 11.8 in.)	W2						
Customer specific length 300 ... < 400 mm (11.8 ... < 15.7 in.)	W4						
Customer specific length 400 ... < 500 mm (15.7 ... < 19.7 in.)	W5						
Customer specific length 500 ... < 600 mm (19.7 ... < 23.6 in.)	W6						
Customer specific length 600 ... < 750 mm (23.6 ... < 29.5 in.)	W7						
Customer specific length 750 ... < 1000 mm (29.5 ... < 39.4 in.)	W8						
Customer specific length 1000 ... < 1500 mm (39.4 ... < 59 in.)	Y1						
Customer specific length 1500 ... < 2000 mm (59 ... < 78.7 in.)	Y3						
Customer specific length 2000 ... < 3000 mm (78.7 ... < 118 in.)	Y5						
Customer specific length 3000 ... < 5000 mm (118 ... < 196.8 in.)	Y7						
Customer specific length 5000 ... < 10000 mm (196.8 ... < 393.7 in.)	Z1						
Nominal Length							
N = 230 mm (9.1 in.)	N1						
N = 290 mm (11.42 in.)	N3						
N = 380 mm (15 in.)	N5						
N = 530 mm (20.9 in.)	N7						
Customer specific length < 150 mm (< 5.9 in.)	W1						
Customer specific length 150 ... < 300 mm (5.9 ... < 11.8 in.)	W2						
Customer specific length 300 ... < 400 mm (11.8 ... < 15.7 in.)	W4						
Customer specific length 400 ... < 500 mm (15.7 ... < 19.7 in.)	W5						
Customer specific length 500 ... < 600 mm (19.7 ... < 23.6 in.)	W6						
Customer specific length 600 ... < 750 mm (23.6 ... < 29.5 in.)	W7						
Customer specific length 750 ... < 1000 mm (29.5 ... < 39.4 in.)	W8						
Customer specific length 1000 ... < 1500 mm (39.4 ... < 59 in.)	Y1						
Customer specific length 1500 ... < 2000 mm (59 ... < 78.7 in.)	Y3						
Customer specific length 2000 ... < 3000 mm (78.7 ... < 118 in.)	Y5						
Customer specific length 3000 ... < 5000 mm (118 ... < 196.8 in.)	Y7						
Measuring Inset Type							
Without measuring inset	Y0						
RTD, Basic application, measuring range -50 ... 400 °C (-58 ... 752 °F), 10 g	S1						
RTD, Extended vibration resistance, measuring range -50 ... 400 °C (-58 ... 752 °F), 60 g	S2						
RTD, Extended measuring range, WW, measuring range -196 ... 600 °C (-321 ... 1112 °F), 10 g	D1						
RTD, Extended measuring range, WW, measuring range -196 ... 600 °C (-321 ... 1112 °F), 3 g	D2						
RTD, adjustable to German calibration regulations, sign of app. 000/308 - without calibration	E1						
Thermocouple	T1						
Others	Z9						

Main ordering information SensyTemp TSP321-W	XX	XX	XX	XX
Sensor Type and Wiring				
1 x Pt100, 2-wire	P1			
1 x Pt100, 3-wire	P2			
1 x Pt100, 4-wire	P3			
2 x Pt100, 2-wire	P4			
2 x Pt100, 3-wire	P5			
1 x Type K (NiCr-NiAl)	K1			
2 x Type K (NiCr-NiAl)	K2			
1 x Type J (Fe-CoNi)	J1			
2 x Type J (Fe-CoNi)	J2			
1 x Type N (NiCrSi-NiSi)	N1			
2 x Type N (NiCrSi-NiSi)	N2			
1 x Type T (Co-CoNi)	T1			
2 x Type T (Co-CoNi)	T2			
1 x Type E (NiCr-CoNi)	E1			
2 x Type E (NiCr-CoNi)	E2			
Sensor Accuracy				
RTD, Accuracy Class B, IEC 60751				B2
Thin Film, Accuracy Class A, IEC 60751, Range -30 ... 350 °C (-22 ... 662 °F)				S1
Wire Wound, Accuracy Class A, IEC 60751, Range -196 ... 500 °C (-321 ... 932 °F)				D1
Wire Wound, Double, Accuracy Class A, IEC 60751, Range 0 ... 250 °C (32 ... 482 °F)				D2
TC, Accuracy Class 2, IEC 60584				T2
TC, Accuracy Class 1, IEC 60584				T1
TF, Accuracy Class AA, IEC 60751, Range 0 ... 100 °C (0 ... 212 °F)				S3
TC, Standard Accuracy ANSI MC96.1				T4
TC, Special Accuracy ANSI MC96.1				T3
Others				Z9
Connection Head Type / Material				
AGLH / Aluminium, high cover, screwed				L2
AGLD / Aluminium, screwed cover with display				L4
AGSH / Stainless steel, high cover, screwed				S2
AGSD / Stainless steel, screwed cover with display				S4
Others				Z9
Transmitter				
WirelessHART				W1

SensyTemp TSP300-W WirelessHART Temperature sensor with Energy Harvester

Additional ordering information SensyTemp TSP321-W

	XX	XX	XX	XX	XX	XX	XX	XX	XX	XX
Declaration of Compliance: 2.1										
Declaration of compliance according EN 10204-2.1, with the order	C4									
Test report: 2.2, Material Monitoring for Wetted Parts										
Test report according EN 10204-2.2, material monitoring for wetted parts	C1									
Test report: 2.2, Batch Values										
Test report according EN 10204-2.2 for batch values, MIC-TC	C5									
Inspection Certificate: 3.1, 3.2, Material Monitoring for Wetted Parts										
Inspection certificate according EN 10204-3.1, material monitoring for wetted parts					C2					
Inspection certificate according EN 10204-3.2, material monitoring for wetted parts					C3					
Inspection Certificate: 3.1, Visual, Dimensional and Functional Test										
Inspection certificate according EN 10204-3.1, visual, dimensional and functional test						C6				
Inspection Certificate: 3.1, Helium Leakage Test										
Inspection certificate according EN 10204-3.1, helium leakage test							C7			
Inspection Certificate: 3.1, Dye Penetration Test										
Inspection certificate according EN 10204-3.1, dye penetration test								C9		
Inspection Certificate: 3.1, PMI Test										
Inspection certificate according EN 10204-3.1, Positive Material Identification (PMI)									CA	
Inspection Certificate: 3.1, Pressure Test										
Inspection certificate according EN 10204-3.1, pressure test on thermowell										CB
Inspection Certificate: 3.1, Sensor Tolerance										
Inspection certificate according EN 10204-3.1, sensor tolerance										CC

Additional ordering information SensyTemp TSP321-W	XX	XX	XX	XX
Certificate: Sensor Calibration				
Inspection certificate according EN 10204-3.1, sensor calibration, single RTD	CD			
Inspection certificate according EN 10204-3.1, sensor calibration, double RTD	CE			
Inspection certificate according EN 10204-3.1, sensor calibration, single thermocouple	CF			
Inspection certificate according EN 10204-3.1, sensor calibration, double thermocouple	CG			
DAkkS sensor calibration, single RTD, calibration certificate per thermometer	CH			
DAkkS sensor calibration, double RTD, calibration certificate per thermometer	CJ			
DAkkS sensor calibration, single thermocouple, calibration certificate per thermometer	CK			
DAkkS sensor calibration, double thermocouple, calibration certificate per thermometer	CL			
Certificate: Other				
Other			CZ	
Number of Calibration Test Points				
1 point				P1
2 points				P2
3 points				P3
4 points				P4
5 points				P5
Temperatures for Sensor Calibration				
Standard calibration: 0 °C (32 °F)				V1
Standard calibration: 100 °C (212 °F)				V2
Standard calibration: 400 °C (752 °F)				V3
Standard calibration: 0 °C and 100 °C (32 °F and 212 °F)				V4
Standard calibration: 0 °C and 400 °C (32 °F and 752 °F)				V5
Standard calibration: 0 °C, 100 °C and 200 °C (32 °F, 212 °F and 392 °F)				V7
Standard calibration: 0 °C, 200 °C and 400 °C (32 °F, 392 °F and 752 °F)				V8
Standard calibration: Customer specific temperatures				V6
DAkkS calibration: 0 °C (32 °F)				D1
DAkkS calibration: 100 °C (212 °F)				D2
DAkkS calibration: 400 °C (752 °F)				D3
DAkkS calibration: 0 °C and 100 °C (32 °F and 212 °F)				D4
DAkkS calibration: 0 °C and 400 °C (32 °F and 752 °F)				D5
DAkkS calibration: 0 °C, 100 °C and 200 °C (32 °F, 212 °F and 392 °F)				D7
DAkkS calibration: 0 °C, 200 °C and 400 °C (32 °F, 392 °F and 752 °F)				D8
DAkkS calibration: Customer specific temperatures				D6

SensyTemp TSP300-W WirelessHART Temperature sensor with Energy Harvester

Additional ordering information SensyTemp TSP321-W	XX	XX	XX	XX	XX
Thermowell Options					
Thermowell stainless steel with additional tantalum sleeve	S1				
Thermowell coated with 0.5 mm (0.02 in.) E-CTFE / Halar, wetted parts incl. flange surface	S2				
Thermowell coated with 0.5 mm (0.02 in.) PFA, wetted parts incl. flange surface	S3				
Thermowell coated with 1 mm (0.04 in.) NiCrB / META 43 (specify length from thermowell tip in mm)	S4				
Thermowell coated with 0.5 mm (0.02 in.) NiZrO2 / PL1312 (specify length from thermowell tip in mm)	S5				
Thermowell clean for oxygen service	S9				
Others	SZ				
Flange Connection Options					
Flange facing with groove form C EN 1092-1		F1			
Flange facing with tongue form D EN 1092-1		F2			
Flange facing with RTJ surface ASME B16.5		F3			
Others		FZ			
Thermometer single packed					
Each Thermometer single packed - Polyethylen				PN	
Documentation Language					
German					M1
English					M5
Name Plate					
Stainless steel plate with TAG no.					T1

Main ordering information SensyTemp TSP331-W

Base model	TSP331-W	XX	XX	XX	XXX	XX	XX	XX	XX	XX	XX	XX	XX	XX	XX
SensyTemp TSP331-W Temperature Sensor, with drilled thermowell, WirelessHART															
Explosion Protection / Approvals				Continued see next page											
Without		Y0													
Intrinsic Safety: ATEX II 1 G Ex ia IIC T4		A6													
Intrinsic Safety: IECEX ia IIC T4		H6													
Wetted Thermowell Material															
Stainless Steel ASTM 316L (1.4404)			S1												
Stainless Steel ASTM 316Ti (1.4571)			S2												
High temperature Steel 13CrMo4-5 (1.7335)			W1												
High temperature Steel 10CrMo9-10 (1.7380)			W2												
High temperature Steel 16Mo3, formerly 15Mo3 (1.5415)			W3												
Stainless steel (1.4961)			W4												
Heat Resistent Steel AISI 446 (1.4749)			H1												
Heat Resistent Steel 1.4762			H2												
Stainless Steel AISI 314 (1.4841)			H3												
Stainless Steel ASTM 904L (1.4539)			S4												
Ni-Alloy Hastelloy C-276 (2.4819)			N1												
Ni-Alloy Hastelloy C-4 (2.4610)			N2												
Ni-Alloy Hastelloy B-2 (2.4617)			N3												
NiCo-Alloy Monel 400 (2.4360)			N4												
Ni-Alloy Incoloy 800 (1.4876)			H4												
Ni-Alloy Inconel 600 (2.4816)			N5												
Stainless Steel ASTM 304 (1.4301)			S5												
Stainless Steel ASTM 321 (1.4541)			S6												
Others			Z9												

SensyTemp TSP300-W WirelessHART Temperature sensor with Energy Harvester

Main ordering information SensyTemp TSP331-W	XX	XXX	XX	XX	XX	XX	XX	XX	XX	XX	XX	XX
Thermowell Type												
Weld-in thermowell from bar stock material, diameter F2 = 24 mm (0.95 in.), (DIN 43772, Form 4)	D1											
Weld-in thermowell from bar stock material, diameter F2 = 18 mm (0.71 in.), (DIN 43772, Form 4)	D2											
Flanged thermowell from bar stock material, diameter F2 = 24 mm (0.95 in.), (DIN 43772, Form 4F)	D3											
Flanged thermowell from bar stock material, diameter F2 = 18 mm (0.71 in.), (DIN 43772, Form 4F)	D4											
Weld-in thermowell from bar stock material, diameter F2 = 32 mm (1.26 in.), (ABB, Form PW)	P1											
Flanged thermowell from bar stock material, (ABB, Form PF)	P2											
Screwed thermowell from bar stock material, tapered tip, (ABB, Form PS)	P3											
Others	Z9											
Process Connection												
Without process connection (weld-in type)	Y00											
Conical thread 1/2 in. NPT	S04											
Conical thread 3/4 in. NPT	S05											
Conical thread 1 in. NPT	S06											
Flange DN 25 PN 10 ... PN 40, B1, EN 1092-1	F03											
Flange DN 40 PN 10 ... PN 40, B1, EN 1092-1	F04											
Flange DN 50 PN 10 ... PN 40, B1, EN 1092-1	F05											
Flange DN 50 PN 6, B1, EN 1092-1	F06											
Flange 1 in. 150 lbs, RF, ASME B16.5	F07											
Flange 1 in. 300 lbs, RF, ASME B16.5	F08											
Flange 1-1/2 in. 150 lbs, RF, ASME B16.5	F11											
Flange 1-1/2 in. 300 lbs, RF, ASME B16.5	F12											
Flange 1-1/2 in. 600 lbs, RF, ASME B16.5	F13											
Flange 1-1/2 in. 900 / 1500 lbs, RF, ASME B16.5	F14											
Flange 2 in. 150 lbs, RF, ASME B16.5	F15											
Flange 2 in. 300 lbs, RF, ASME B16.5	F16											
Flange 2 in. 600 lbs, RF, ASME B16.5	F17											
Flange 2 in. 900 / 1500 lbs, RF, ASME B16.5	F18											
Others	Z99											

Main ordering information SensyTemp TSP331-W	XX	XX	XX	XX	XX	XX	XX	XX	XX
Extension Tube Length									
K = 242 mm (9.5 in.), free length up to cooling element = 152 mm (6 in.), Harvester	H1								
K = 267 mm (10.5 in.), free length up to cooling element = 152 mm (6 in.), Harvester, adapter 25 mm (1 in.)	H2								
K = 292 mm (11.5 in.), free length up to cooling element = 152 mm (6 in.), Harvester, adapter 50 mm (2 in.)	H3								
K = 317 mm (12.5 in.), free length up to cooling element = 152 mm (6 in.), Harvester, adapter 75 mm (3 in.)	H4								
K = 342 mm (13.5 in.), free length up to cooling element = 152 mm (6 in.), Harvester, adapter 100 mm (4 in.)	H5								
K = 150 mm (6 in.)	K1								
Customer specific length < 150 mm (< 5.9 in.)	W1								
Customer specific length 150 ... < 300 mm (5.9 ... < 11.8 in.)	W2								
Customer specific length 300 ... < 400 mm (11.8 ... < 15.7 in.)	W4								
Customer specific length 400 ... < 500 mm (15.7 ... < 19.7 in.)	W5								
Customer specific length 500 ... < 600 mm (19.7 ... < 23.6 in.)	W6								
Customer specific length 600 ... < 750 mm (23.6 ... < 29.5 in.)	W7								
Customer specific length 750 ... < 1000 mm (29.5 ... < 39.4 in.)	W8								
Customer specific length 1000 ... < 1500 mm (39.4 ... < 59 in.)	Y1								
Customer specific length 1500 ... < 2000 mm (59 ... < 78.7 in.)	Y3								
Thermowell Connection									
Extension tube with Cylindrical thread M14 x 1,5	M1								
Extension tube with Cylindrical thread M18 x 1,5	M2								
Extension tube with conygal thread 1/2 in. NPT	N1								
Extension with Male nut, thread G 1/2 in.	U6								
Nipple / 1/2 in. NPT / 1/2 in. NPT	N2								
Nipple-Union / 1/2 in. NPT / Union 1/2 in. NPT	N3								
Nipple - Union - Nipple / 1/2 in. NPT / 1/2 in. NPT	N4								
Others	Z9								
Immersion Length									
Without fixed immersion length	Y0								
U = 130 mm (5.2 in.)	D1								
U = 190 mm (7.5 in.)	D2								
U = 340 mm (13.4 in.)	D3								
U = 100 mm (4 in.)	P1								
U = 150 mm (6 in.)	P2								
U = 200 mm (8 in.)	P3								
U = 250 mm (10 in.)	P4								
U = 300 mm (12 in.)	P5								
U = 350 mm (14 in.)	P6								
Customer specific length < 150 mm (< 5.9 in.)	W1								
Customer specific length 150 ... < 300 mm (5.9 ... < 11.8 in.)	W2								
Customer specific length 300 ... < 400 mm (11.8 ... < 15.7 in.)	W4								
Customer specific length 400 ... < 500 mm (15.7 ... < 19.7 in.)	W5								
Customer specific length 500 ... < 600 mm (19.7 ... < 23.6 in.)	W6								
Customer specific length 600 ... < 750 mm (23.6 ... < 29.5 in.)	W7								
Customer specific length 750 ... < 1000 mm (29.5 ... < 39.4 in.)	W8								
Customer specific length 1000 ... < 1500 mm (39.4 ... < 59 in.)	Y1								

SensyTemp TSP300-W WirelessHART

Temperature sensor with Energy Harvester

Main ordering information SensyTemp TSP331-W	XX	XX	XX	XX	XX	XX
Thermowell Length						
L = 110 mm (4.4 in.), C = 65 mm (2.5 in.)	D1					
L = 115 mm (4.6 in.), C = 40 mm (1.5 in.)	D2					
L = 140 mm (5.6 in.), C = 65 mm (2.5 in.)	D3					
L = 200 mm (8 in.), C = 65 mm (2.5 in.)	D4					
L = 200 mm (8 in.), C = 125 mm (5 in.)	D5					
L = 260 mm (10.3 in.), C = 125 mm (5 in.)	D6					
L = 410 mm (16.2 in.), C = 275 mm (10.9 in.)	D7					
L = 146 mm (5.8 in.)	R1					
L = 175 mm (6.9 in.)	R2					
L = 265 mm (10.5 in.)	R3					
L = 415 mm (16.4 in.)	R4					
L = U + 65 mm (2.5 in.) - European standard	P1					
Custom specification	D9					
Others	Z9					
Measuring Inset Type						
Without measuring inset	Y0					
RTD, Basic application, measuring range -50 ... 400 °C (-58 ... 752 °F), 10 g	S1					
RTD, Extended vibration resistance, measuring range -50 ... 400 °C (-58 ... 752 °F), 60 g	S2					
RTD, Extended measuring range, WW, measuring range -196 ... 600 °C (-321 ... 1112 °F), 10 g	D1					
RTD, Extended measuring range, WW, measuring range -196 ... 600 °C (-321 ... 1112 °F), 3 g	D2					
RTD, adjustable to German calibration regulations, sign of app. 000/308 - without calibration	E1					
Thermocouple	T1					
Others	Z9					
Sensor Type and Wiring						
1 x Pt100, 2-wire				P1		
1 x Pt100, 3-wire				P2		
1 x Pt100, 4-wire				P3		
2 x Pt100, 2-wire				P4		
2 x Pt100, 3-wire				P5		
1 x Type K (NiCr-NiAl)				K1		
2 x Type K (NiCr-NiAl)				K2		
1 x Type J (Fe-CoNi)				J1		
2 x Type J (Fe-CoNi)				J2		
1 x Type N (NiCrSi-NiSi)				N1		
2 x Type N (NiCrSi-NiSi)				N2		
1 x Type T (Co-CoNi)				T1		
2 x Type T (Co-CoNi)				T2		
1 x Type E (NiCr-CoNi)				E1		
2 x Type E (NiCr-CoNi)				E2		

Main ordering information SensyTemp TSP331-W	XX	XX	XX
Sensor Accuracy			
RTD, Accuracy Class B, IEC 60751	B2		
Thin Film, Accuracy Class A, IEC 60751, Range -30 ... 350 °C (-22 ... 662 °F)	S1		
Wire Wound, Accuracy Class A, IEC 60751, Range -196 ... 500 °C (-321 ... 932 °F)	D1		
Wire Wound, Double, Accuracy Class A, IEC 60751, Range 0 ... 250 °C (32 ... 482 °F)	D2		
TC, Accuracy Class 2, IEC 60584	T2		
TC, Accuracy Class 1, IEC 60584	T1		
TF, Accuracy Class AA, IEC 60751, Range 0 ... 100 °C (0 ... 212 °F)	S3		
TC, Standard Accuracy ANSI MC96.1	T4		
TC, Special Accuracy ANSI MC96.1	T3		
Others	Z9		
Connection Head Type / Material			
AGLH / Aluminium, high cover, screwed		L2	
AGLD / Aluminium, screwed cover with display		L4	
AGSH / Stainless steel, high cover, screwed		S2	
AGSD / Stainless steel, screwed cover with display		S4	
Transmitter			
WirelessHART			W1
WirelessHART + Harvester			W3

SensyTemp TSP300-W WirelessHART Temperature sensor with Energy Harvester

Additional ordering information SensyTemp TSP331-W

	XX	XX	XX	XX	XX	XX	XX	XX	XX	XX
Declaration of Compliance: 2.1										
Declaration of compliance according EN 10204-2.1, with the order	C4									
Test report: 2.2, Material Monitoring for Wetted Parts										
Test report according EN 10204-2.2, material monitoring for wetted parts	C1									
Test report: 2.2, Batch Values										
Test report according EN 10204-2.2 for batch values, MIC-TC	C5									
Inspection Certificate: 3.1, 3.2, Material Monitoring for Wetted Parts										
Inspection certificate according EN 10204-3.1, material monitoring for wetted parts				C2						
Inspection certificate according EN 10204-3.2, material monitoring for wetted parts				C3						
Inspection Certificate: 3.1, Visual, Dimensional and Functional Test										
Inspection certificate according EN 10204-3.1, visual, dimensional and functional test					C6					
Inspection Certificate: 3.1, Helium Leakage Test										
Inspection certificate according EN 10204-3.1, helium leakage test						C7				
Inspection Certificate: 3.1, Dye Penetration Test										
Inspection certificate according EN 10204-3.1, dye penetration test							C9			
Inspection Certificate: 3.1, PMI Test										
Inspection certificate according EN 10204-3.1, Positive Material Identification (PMI)								CA		
Inspection Certificate: 3.1, Pressure Test										
Inspection certificate according EN 10204-3.1, pressure test on thermowell									CB	
Inspection Certificate: 3.1, Sensor Tolerance										
Inspection certificate according EN 10204-3.1, sensor tolerance										CC

Additional ordering information SensyTemp TSP331-W	XX	XX	XX	XX
Certificate: Sensor Calibration				
Inspection certificate according EN 10204-3.1, sensor calibration, single RTD	CD			
Inspection certificate according EN 10204-3.1, sensor calibration, double RTD	CE			
Inspection certificate according EN 10204-3.1, sensor calibration, single thermocouple	CF			
Inspection certificate according EN 10204-3.1, sensor calibration, double thermocouple	CG			
DAkkS sensor calibration, single RTD, calibration certificate per thermometer	CH			
DAkkS sensor calibration, double RTD, calibration certificate per thermometer	CJ			
DAkkS sensor calibration, single thermocouple, calibration certificate per thermometer	CK			
DAkkS sensor calibration, double thermocouple, calibration certificate per thermometer	CL			
Certificate: Other				
Other			CZ	
Number of Calibration Test Points				
1 point				P1
2 points				P2
3 points				P3
4 points				P4
5 points				P5
Temperatures for Sensor Calibration				
Standard calibration: 0 °C (32 °F)				V1
Standard calibration: 100 °C (212 °F)				V2
Standard calibration: 400 °C (752 °F)				V3
Standard calibration: 0 °C and 100 °C (32 °F and 212 °F)				V4
Standard calibration: 0 °C and 400 °C (32 °F and 752 °F)				V5
Standard calibration: 0 °C, 100 °C and 200 °C (32 °F, 212 °F and 392 °F)				V7
Standard calibration: 0 °C, 200 °C and 400 °C (32 °F, 392 °F and 752 °F)				V8
Standard calibration: Customer specific temperatures				V6
DAkkS calibration: 0 °C (32 °F)				D1
DAkkS calibration: 100 °C (212 °F)				D2
DAkkS calibration: 400 °C (752 °F)				D3
DAkkS calibration: 0 °C and 100 °C (32 °F and 212 °F)				D4
DAkkS calibration: 0 °C and 400 °C (32 °F and 752 °F)				D5
DAkkS calibration: 0 °C, 100 °C and 200 °C (32 °F, 212 °F and 392 °F)				D7
DAkkS calibration: 0 °C, 200 °C and 400 °C (32 °F, 392 °F and 752 °F)				D8
DAkkS calibration: Customer specific temperatures				D6

SensyTemp TSP300-W WirelessHART Temperature sensor with Energy Harvester

Additional ordering information SensyTemp TSP331-W	XX	XX	XX	XX	XX	XX
Thermowell Options						
Thermowell coated with 0.5 mm (0.02 in.) E-CTFE / Halar, wetted parts incl. flange surface	S2					
Thermowell coated with 0.5 mm (0.02 in.) PFA, wetted parts incl. flange surface	S3					
Thermowell coated with 1 mm (0.04 in.) NiCrB / META 43 (specify length from thermowell tip in mm)	S4					
Thermowell coated with 0.5 mm (0.02 in.) NiZrO2 / PL1312 (specify length from thermowell tip in mm)	S5					
Thermowell incl. tests and certificates AD-2000 standard for austenitic steel	S6					
Thermowell incl. tests and certificates AD-2000 standard for high temperature steel	S7					
Thermowell incl. tests and certificates NACE MR 01-75	S8					
Thermowell clean for oxygen service	S9					
Others	SZ					
Thermowell Stress Calculations						
Thermowell stress calculation according Dittrich / Kohler						SD
Thermowell stress calculation according Murdock						SM
Flange Connection Options						
Flange facing with groove form C EN 1092-1						F1
Flange facing with tongue form D EN 1092-1						F2
Flange facing with RTJ surface ASME B16.5						F3
Flange full penetration welded						F4
Others						FZ
Thermometer single packed						
Each Thermometer single packed - Polyethylen						PN
Documentation Language						
German						M1
English						M5
Name Plate						
Stainless steel plate with TAG no.						T1

Main ordering information SensyTemp TSP341-W

Base model	TSP341-W	XX	XXX	XX	XX	XX	XX	XX	XX	XX	XX		
SensyTemp TSP341-W Temperature Sensor, Clamp-on, WirelessHART							Continued see next page						
Explosion Protection / Approvals													
Without													Y0
Intrinsic Safety: ATEX II 1 G Ex ia IIC T4													A6
Intrinsic Safety: IECEx ia IIC T4							H6						
Sensor Mounting													
Clamp-on, sensor in 90° angle to pipe							Y11						
Clamp-on, sensor attached alongside to pipe 1.4571							Y22						
Clamp-on, sensor attached alongside to pipe 1.4404							Y23						
Pipe Diameter													
DN150							C1						
DN200							C2						
DN300							C3						
DN400							C4						
DN500							C5						
Others							Z9						
Extension Tube Length													
K = 242 mm (9.5 in.), free length up to cooling element = 152 mm (6 in.), Harvester							H1						
K = 267 mm (10.5 in.), free length up to cooling element = 152 mm (6 in.), Harvester, adapter 25 mm (1 in.)							H2						
K = 292 mm (11.5 in.), free length up to cooling element = 152 mm (6 in.), Harvester, adapter 50 mm (2 in.)							H3						
K = 317 mm (12.5 in.), free length up to cooling element = 152 mm (6 in.), Harvester, adapter 75 mm (3 in.)							H4						
K = 342 mm (13.5 in.), free length up to cooling element = 152 mm (6 in.), Harvester, adapter 100 mm (4 in.)							H5						
K = 150 mm (6 in.)							K1						
Customer specific length 150 ... < 300 mm (5.9 ... < 11.8 in.)							W2						
Customer specific length 300 ... < 400 mm (11.8 ... < 15.7 in.)							W4						
Customer specific length 400 ... < 500 mm (15.7 ... < 19.7 in.)							W5						
Measuring Inset Type													
RTD, Basic application, measuring range -50 ... 400 °C (-58 ... 752 °F), 10 g							S1						
RTD, Extended vibration resistance, measuring range -50 ... 400 °C (-58 ... 752 °F), 60 g							S2						
RTD, Extended measuring range, WW, measuring range -196 ... 600 °C (-321 ... 1112 °F), 10 g							D1						
RTD, Extended measuring range, WW, measuring range -196 ... 600 °C (-321 ... 1112 °F), 3 g							D2						
Thermocouple							T1						

SensyTemp TSP300-W WirelessHART Temperature sensor with Energy Harvester

Main ordering information SensyTemp TSP341-W	XX	XX	XX	XX
Sensor Type and Wiring				
1 x Pt100, 2-wire	P1			
1 x Pt100, 3-wire	P2			
1 x Pt100, 4-wire	P3			
2 x Pt100, 2-wire	P4			
2 x Pt100, 3-wire	P5			
1 x Type K (NiCr-NiAl)	K1			
2 x Type K (NiCr-NiAl)	K2			
1 x Type J (Fe-CoNi)	J1			
2 x Type J (Fe-CoNi)	J2			
1 x Type N (NiCrSi-NiSi)	N1			
2 x Type N (NiCrSi-NiSi)	N2			
1 x Type T (Co-CoNi)	T1			
2 x Type T (Co-CoNi)	T2			
1 x Type E (NiCr-CoNi)	E1			
2 x Type E (NiCr-CoNi)	E2			
Sensor Accuracy				
RTD, Accuracy Class B, IEC 60751		B2		
Thin Film, Accuracy Class A, IEC 60751, Range -30 ... 350 °C (-22 ... 662 °F)		S1		
Wire Wound, Accuracy Class A, IEC 60751, Range -196 ... 500 °C (-321 ... 932 °F)		D1		
Wire Wound, Double, Accuracy Class A, IEC 60751, Range 0 ... 250 °C (32 ... 482 °F)		T2		
TC, Accuracy Class 2, IEC 60584		T1		
TC, Accuracy Class 1, IEC 60584		T4		
TC, Standard Accuracy ANSI MC96.1		T3		
Connection Head Type / Material				
AGLH / Aluminium, high cover, screwed			L2	
AGLD / Aluminium, screwed cover with display			L4	
AGSH / Stainless steel, high cover, screwed			S2	
AGSD / Stainless steel, screwed cover with display			S4	
Transmitter				
WirelessHART				W1
WirelessHART + Harvester				W3

Additional ordering information SensyTemp TSP341-W

	XX	XX	XX	XX	XX	XX	XX
Declaration of Compliance: 2.1							
Declaration of compliance according EN 10204-2.1, with the order	C4						
Test report: 2.2, Batch Values							
Test report according EN 10204-2.2 for batch values, MIC-TC		C5					
Inspection Certificate: 3.1, Visual, Dimensional and Functional Test							
Inspection certificate according EN 10204-3.1, visual, dimensional and functional test			C6				
Inspection Certificate: 3.1, Sensor Tolerance							
Inspection certificate according EN 10204-3.1, sensor tolerance						CC	
Certificate: Sensor Calibration							
Inspection certificate according EN 10204-3.1, sensor calibration, single RTD							CD
Inspection certificate according EN 10204-3.1, sensor calibration, double RTD							CE
Inspection certificate according EN 10204-3.1, sensor calibration, single thermocouple							CF
Inspection certificate according EN 10204-3.1, sensor calibration, double thermocouple							CG
DAkkS sensor calibration, single RTD, calibration certificate per thermometer							CH
DAkkS sensor calibration, double RTD, calibration certificate per thermometer							CJ
DAkkS sensor calibration, single thermocouple, calibration certificate per thermometer							CK
DAkkS sensor calibration, double thermocouple, calibration certificate per thermometer							CL
Certificate: Other							
Other							CZ
Number of Calibration Test Points							
1 point							P1
2 points							P2
3 points							P3
4 points							P4
5 points							P5

SensyTemp TSP300-W WirelessHART Temperature sensor with Energy Harvester

Additional ordering information SensyTemp TSP341-W	XX	XX	XX
Temperatures for Sensor Calibration			
Standard calibration: 0 °C (32 °F)	V1		
Standard calibration: 100 °C (212 °F)	V2		
Standard calibration: 400 °C (752 °F)	V3		
Standard calibration: 0 °C and 100 °C (32 °F and 212 °F)	V4		
Standard calibration: 0 °C and 400 °C (32 °F and 752 °F)	V5		
Standard calibration: 0 °C, 100 °C and 200 °C (32 °F, 212 °F and 392 °F)	V7		
Standard calibration: 0 °C, 200 °C and 400 °C (32 °F, 392 °F and 752 °F)	V8		
Standard calibration: Customer specific temperatures	V6		
DAkKS calibration: 0 °C (32 °F)	D1		
DAkKS calibration: 100 °C (212 °F)	D2		
DAkKS calibration: 400 °C (752 °F)	D3		
DAkKS calibration: 0 °C and 100 °C (32 °F and 212 °F)	D4		
DAkKS calibration: 0 °C and 400 °C (32 °F and 752 °F)	D5		
DAkKS calibration: 0 °C, 100 °C and 200 °C (32 °F, 212 °F and 392 °F)	D7		
DAkKS calibration: 0 °C, 200 °C and 400 °C (32 °F, 392 °F and 752 °F)	D8		
DAkKS calibration: Customer specific temperatures	D6		
Documentation Language			
German		M1	
English		M5	
Name Plate			
Stainless steel plate with TAG no.			T1

Accessories	Order code
Lithium battery	3KXT000029U0000
TSP300-W Commissioning Instruction, German	3KXT161300R4403
TSP300-W Commissioning Instruction, English	3KXT161300R4401
TSP300-W Commissioning Instruction, Language package Western Europe / Scandinavia	3KXT161300R4493
TSP300-W Commissioning Instruction, Language package Eastern Europe	3KXT161300R4494
TSP300-W Documentation CD-ROM	3KXT161300R0800

Customer-specific configuration

Configuration	Selection
Measurement type (for 2-sensor selection only)	<input type="checkbox"/> Sensor redundancy / sensor backup <input type="checkbox"/> Sensor drift monitoring ____ °C / K sensor drift difference ____ s time limit for drift overshoot <input type="checkbox"/> Difference measurement <input type="checkbox"/> Average measurement
Software write protection	<input type="checkbox"/> Off (standard) <input type="checkbox"/> On
TAG number	<input type="checkbox"/> _____
Long TAG number	<input type="checkbox"/> _____
Network ID	<input type="checkbox"/> Hexadecimal value ABB standard or _____
Join key	<input type="checkbox"/> Hexadecimal value ABB standard or _____ <input type="checkbox"/> Hexadecimal value ABB standard or _____ <input type="checkbox"/> Hexadecimal value ABB standard or _____ <input type="checkbox"/> Hexadecimal value ABB standard or _____

Trademarks

® WirelessHART is a registered trademark of FieldComm Group, Austin, Texas, USA

Contact us

ABB Limited

Process Automation

Howard Road, St. Neots
Cambridgeshire, PE19 8EU
UK

Tel: +44 (0)870 600 6122

Fax: +44 (0)1480 213 339

Mail: enquiries.mp.uk@gb.abb.com

ABB Inc.

Process Automation

125 E. County Line Road
Warminster, PA 18974
USA

Tel: +1 215 674 6000

Fax: +1 215 674 7183

ABB Automation Products GmbH

Process Automation

Schillerstr. 72
32425 Minden
Germany

Tel: +49 571 830-0

Fax: +49 571 830-1806

www.abb.com/temperature

SEITA

Soluciones en Instrumentación,
Automatización y Control Industrial

www.seita.com.co

Note

We reserve the right to make technical changes or modify the contents of this document without prior notice.

With regard to purchase orders, the agreed particulars shall prevail. ABB does not accept any responsibility whatsoever for potential errors or possible lack of information in this document.

We reserve all rights in this document and in the subject matter and illustrations contained therein. Any reproduction, disclosure to third parties or utilization of its contents – in whole or in parts – is forbidden without prior written consent of ABB.

Copyright© 2016 ABB

All rights reserved

3KXT161300R1001



Sales



Service