

control valve with rotary globe type BR 33



strong
arguments
of modern technology

rotary globe control valve

application

Rotary plug control valves BR 33 represent the design of valves, where change in flow ratio is achieved through eccentrically set rotary plug.

Such structures are particularly useful for control of flow under heavy-duty conditions, with high probability of cavitation and erosion.

High rangeability (200:1) and wide range of material and design variants make them ideal for application in many branches of industry, such as power generation, metallurgy, chemical and petroleum industry, food industry, paper industry, etc.

features

- one-piece valve body (cast with bonnet), no static or dynamic sealing except shaft sealing chamber
- no „detachment effect“ between plug and seat
- ability to change Kvs without changing plug or seat
- easy replacement of rotary, symmetrical plug
- elongated bonnet allows application of double sealing for shaft, meeting „low emission“ standards equal to „TA-Luft“ conditions
- the same Kvs coefficients for „hard“ and „soft“ seats
- leakage class less than 0.01% Kvs for „hard“ seats („metal-metal“)
- same flow direction for „hard“ and „soft“ seats
- valve-actuator connection accessible from outside, which allows pivoting actuator to valve axis by 90° increments
- special executions: with heat jacket, erosion-proof, for crystallizable media

design and technical specifications

body (1)	flanged or flangeless, cast in cast steel
nominal sizes	DN 25; 40; 50; 80; 100; 150; 200; 250; 300
nominal pressures	PN 10; 16; 25; 40 (as per PN-EN 1092-1:2006); CL 150; CL 300 (as per PN-EN 1759-1:2005)

Steel flanges CL150; CL300 are so designed that they can be assembled with flanges executed per American standards ANSI/ASME B16.5 and MSS SP44. In American standards flanges are identified with nominal values in „Classes“, to which nominal pressure (PN) values as per PN-ISO 7005-1:2002 correspond. Equivalent identification as per PN are: CL 150 \triangleq PN 20 and CL 300 \triangleq PN 50.

nominal pressures and end connections

Nominal pressure	Facing of flange types			
	Raised face	Groove	Recess	Ring-joint
PN10; 16; 25; 40	B	D	F	-
CL 150	B (RF)	-	-	
CL 300		DL (D1)	F (F1)	
() - identification of connections as per ASME B16.5				

face to face dimensions

flanged valves as per PN-EN 60534-3-1:2000; as per ANSI B16.10:1992

flangeless (sandwich) as per PN-EN 60534-3-2:2002

bridge (2) functions as rotary closure, cast in grey iron or steel (welded)

valve plug (3) working piece in the form of globe section:

flow characteristics linear (L)

equal percentage (P) only with positioner

rangeability: 200 : 1

valve seat (4)

loosely resting in body opening; susceptible to fitting to spherical cap of valve plug

hard / soft (with PTFE sealing)

leakage class

basic: class IV as per PN-EN 60534-4 - metallic seat

bubble-tight: class VI as per PN-EN 60534-4 - soft seat

screw plug (5)

fixing seat to body (medium flow direction „under plug“); in special executions its function is preventing erosion (medium flow direction „above plug“)

shaft (6)

transmits torque from actuator to valve plug: burnished, with polished sealing interface

guiding sleeves of plug (7) and shaft (8)

function as slide bearings; surface hardened (CrN coating) or PTFE coated

packing (9)

packing kits formed in various materials (PTFE-V; PTFE+graphite; braided or expanded graphite); special „low emission“ kit, with follower sprigs TA-Luft

packaging types with application ranges

Materials	Nominal pressure PN / CL	Temperature [°C]
PTFE - V	PN10 - 40 CL150 CL 300	-46 ... +200
PTFE + Graphite		
PTFE - V / TA-Luft		+200 ... +250
Graphite		(+200 ... +450) *
Graphite / TA-Luft		

* - drive retracted from valve (extended yoke)

listing of components with materials

Item	Component	Materials			
		GP240GH; (1.0619)	WCB	GX5CrNiMo 19-11-2; (1.4408)	CF8M
1	body				
2	bridge				
3	plug	X6CrNiMoTi 17-12-2 (1.4571); X6CrNiMoTi 17-12-2 + stellit X2CrNiMoTi 17-12-2 (1.4404); X2CrNiMoTi 17-12-2 + stellit			
4a	metallic seat	X6CrNiMoTi 17-12-2 (1.4571); X6CrNiMoTi 17-12-2 + stellit X2CrNiMoTi 17-12-2 (1.4404); X2CrNiMoTi 17-12-2 + stellit			
4b	soft Seat	X6CrNiMoTi 17-12-2 + PTFE; X2CrNiMoTi 17-12-2 + PTFE			
5	screw plug	X6CrNiMoTi 17-12-2 (1.4571)			
6	shaft	X6CrNiMoTi 17-12-2 (1.4571)			
7	guiding sleeve	X6CrNiMoTi 17-12-2 (1.4571) + CrN			
8	shaft sealing	X6CrNiMoTi 17-12-2 + PTFE			
9	packing kit	PTFE-V; PTFE + grafit; GRAFIT			
10a, 10b	sealing ring	FKM			
11	sweep ring	VMQ			
12	disk spring	12R10 (SANDVIK)			
13	spacer sleeve	X6CrNiMoTi 17-12-2 (1.4571)			
14	lubricating sleeve	X6CrNiMoTi 17-12-2 (1.4571)			
15	follower sleeve	X6CrNiMoTi 17-12-2 (1.4571)			
16	pressing lever	X6CrNiMoTi 17-12-2 (1.4571); GX5CrNiMo 19-11-2 (1.4408)			
17	cylindrical pin	X6CrNiMoTi 17-12-2 (1.4571)			
18	conical pin	X6CrNiMoTi 17-12-2 (1.4571)			
19	stud bolt	8.8			A4-70
20	nut	8			A4-70
Material relevant standard					
Material		Standard			
GP240GH (1.0619)		PN-EN 10213-2			
WCB		ASTM A 216			
GX5CrNiMo19-11-2 (1.4408)		PN-EN 10213-4			
CF8M		ASTM A 351			
X6CrNiMoTi 17-12-2 (1.4571)		PN-EN 10088			
X2CrNiMoTi 17-12-2 (1.4404)		PN-EN 10088			
Notes					
= Spare part					

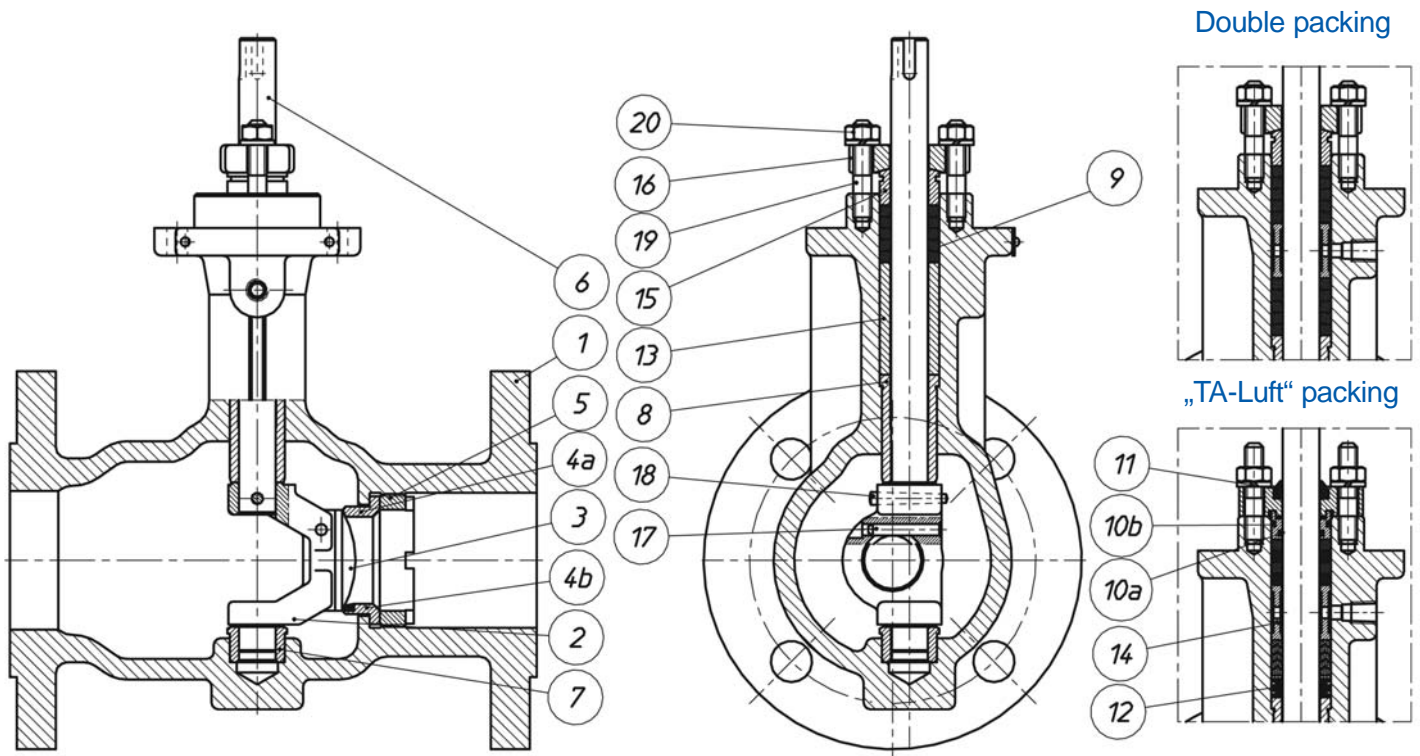

allowable working overpressure for materials at proper temperatures

Material: GP240GH (1.0619) as per PN-EN 10213-2										
PN/CL	Standard	Temperature [°C]								
		-10...50	100	150	200	250	300	350	400	
		Allowable working pressure [bar]								
PN10	EN 1092-1	10	9,3	8,7	7,8	7,1	6,4	6	5,8	
PN16		16	14,9	13,9	12,4	11,4	10,3	9,6	9,2	
CL150	PN-EN 1759-1	17,3	15,4	14,6	13,8	12,1	10,2	8,4	6,5	
PN25	EN 1092-1	25	23,3	21,7	19,4	17,8	16,1	15	14,4	
PN40		40	37,3	34,7	30,2	28,4	25,8	24	23,1	
CL150	PN-EN 1759-1	45,3	40,1	38,1	36	32,9	29,8	27,8	25,7	

Material: GX5CrNiMo 19-11-2 (1.4408) as per PN-EN 10213-4											
PN/CL	Standard	Temperature [°C]									
		-10...50	100	150	200	250	300	350	400	425	450
		Allowable working pressure [bar]									
PN10	EN 1092-1	8,7	7,8	7	6,4	6	5,6	5,3	5,1	-	5
PN16		13,9	12,4	11,2	10,3	9,6	9	8,5	8,2	-	8
CL150	PN-EN 1759-1	17,9	16,3	14,9	13,5	12,1	10,2	8,4	6,5	5,6	4,7
PN25	EN 1092-1	22,8	21,1	19,6	18,3	17,2	16,1	15,6	15	-	14,8
PN40		34,7	31,1	28,1	25,8	24	22,6	21,3	20,4	-	20,1
CL150	PN-EN 1759-1	46,7	42,5	38,9	35,3	32,9	30,5	28,8	27,6	27,2	26,9

Material: WCB as per ASTM A216										
PN/CL	Standard	Temperature [°C]								
		-10...50	100	150	200	250	300	350	375	400
		Allowable working pressure [bar]								
PN10	EN 1092-1	10	10	9,7	9,4	9	8,3	7,9	7,7	6,7
PN16		16	16	15,6	15,1	14,4	13,4	12,8	12,4	10,8
CL150	PN-EN 1759-1	19,3	17,7	15,8	14	12,1	10,2	8,4	7,4	6,5
PN25	EN 1092-1	25	25	24,4	23,7	22,5	20,9	20	19,4	16,9
PN40		40	40	39,1	37,9	36	33,5	31,9	31,1	27
CL150	PN-EN 1759-1	50	46,4	45,1	43,9	41,8	38,9	36,9	36,6	34,6

Material: CF8M as per ASTM A351												
PN/CL	Standard	Temperature [°C]										
		-10...50	100	150	200	250	300	350	375	400	425	450
		Allowable working pressure [bar]										
PN10	EN 1092-1	8,9	7,8	7,1	6,6	6,1	5,8	5,6	5,5	5,4	5,4	5,3
PN16		14,3	12,5	11,4	10,6	9,8	9,3	9	8,8	8,7	8,6	8,5
CL150	PN-EN 1759-1	18,4	16	14,8	13,6	12	10,2	8,4	7,4	6,5	5,6	4,6
PN25	EN 1092-1	22,3	19,5	17,8	16,5	15,5	14,6	14,1	13,8	13,6	13,5	13,4
PN40		35,6	31,3	28,5	26,4	24,7	23,4	22,6	22,1	21,8	21,6	21,4
CL150	PN-EN 1759-1	48,1	42,3	38,6	35,8	33,5	31,6	30,4	29,6	29,3	29	29

- Notes:**
1. It is allowed to apply carbon steel up to -60° C, and acid proof steel up to -196° C, provided that working pressure is reduced respectively, working temperature impact tests are performed and cast is heat treated.
 2. Working pressure for intermediate temperature values can be calculated by interpolation.

Kvs- and pressure difference table

valve with „metal“ seat (leakage class IV)

mode of action (air to open)

type of actuator						99R-I-NT (120 cm ²)		99R-II-NT (240 cm ²)		99R-III-NT (780 cm ²)	
spring range (bar)						1,0-2,0	1,6-3,2	0,8-1,6	1,6-3,2	1,0-2,0	1,6-3,2
DN	Kvs 100 %	Kvs 75 %	Kvs 45 %	Kvs ** 120 %	seat mm	maximum allowable pressure difference (bar)		maximum allowable pressure difference (bar)		maximum allowable pressure difference (bar)	
25	15	11	7	18	18	50 *	-	-	-	-	-
25	6	5	3	7	12	50 *	-	-	-	-	-
40	40	30	18	48	285	50 *	-	-	-	-	-
40	16	12	7	19	20	50 *	-	-	-	-	-
50	60	45	27	72	38	50 *	-	-	-	-	-
50	24	18	11	29	26	50 *	-	-	-	-	-
80	150	113	68	180	58	11	32	50 *	50 *	-	-
80	60	45	27	72	38	33	50 *	50 *	50 *	-	-
100	240	180	108	288	72	2	13	27	50 *	-	-
100	96	72	43	115	48	11	36	50 *	50 *	-	-
150	500	375	225	600	110	-	-	9	23	50 *	50 *
150	200	150	90	240	72	-	-	25	50 *	50 *	50 *
200	800	600	360	960	136	-	-	-	103	44	50 *
200	320	240	144	384	88	-	-	-	307	50 *	50 *
250	1250	938	563	1500	170	-	-	-	5	20	45
250	500	375	225	600	110	-	-	-	17	50 *	50 *
300	1800	1350	810	2160	200	-	-	-	2	12	28
300	720	540	324	864	126	-	-	-	10	34	50 *

* don't exceed the nominal pressure of the flanged end / ** at a setting of 120 % the maximum possible pressure differences are reduced

valve with „soft“ seat (leakage class VI)

mode of action (air to open)

type of actuator						99R-I-NT (120 cm ²)		99R-II-NT (240 cm ²)		99R-III-NT (780 cm ²)	
spring range (bar)						1,0-2,0	1,6-3,2	0,8-1,6	1,6-3,2	1,0-2,0	1,6-3,2
DN	Kvs 100 %	Kvs 75 %	Kvs 45 %	Kvs ** 120 %	seat mm	maximum allowable pressure difference (bar)		maximum allowable pressure difference (bar)		maximum allowable pressure difference (bar)	
25	15	11	7	18	18	50 *	-	-	-	-	-
25	6	5	3	7	12	50 *	-	-	-	-	-
40	40	30	18	48	285	50 *	-	-	-	-	-
40	16	12	7	19	20	50 *	-	-	-	-	-
50	60	45	27	72	38	50 *	-	-	-	-	-
50	24	18	11	29	26	50 *	-	-	-	-	-
80	150	113	68	180	56	14	35	50 *	50 *	-	-
80	60	45	27	72	38	38	50 *	50 *	50 *	-	-
100	240	180	108	288	72	5	16	30	50 *	-	-
100	96	72	43	115	48	15	40	50 *	50 *	-	-
150	500	375	225	600	110	-	-	10	25	50 *	50 *
150	200	150	90	240	72	-	-	28	50 *	50 *	50 *
200	800	600	360	960	136	-	-	-	15	38	50 *
200	320	240	144	384	88	-	-	-	39	50 *	50 *
250	1250	938	563	1500	170	-	-	-	6	18	39
250	500	375	225	600	110	-	-	-	19	48 *	50 *
300	1800	1350	810	2160	200	-	-	-	3	11	25
300	720	540	324	864	126	-	-	-	11	30	50 *

* don't exceed the nominal pressure of the flanged end / ** at a setting of 120 % the maximum possible pressure differences are reduced

Calculated ratios: $F_L = 0,854$, $X_T = 0,6$, $F_D = 0,7$, $x_{F_Z} = 0,58$

Kvs- and pressure difference table

valve with „metal“ seat (leakage class IV)

mode of action (air to close)

type of actuator - spring range 0,8 - 1,6 bar						99P-I-NT (120 cm ²)		99P-II-NT (240 cm ²)		99P-III-NT (780 cm ²)	
supply pressure (bar)						2,4	4,0	2,4	4,0	2,4	4,0
DN	Kvs 100 %	Kvs 75 %	Kvs 45 %	Kvs ** 120 %	seat mm	maximum allowable pressure difference (bar)		maximum allowable pressure difference (bar)		maximum allowable pressure difference (bar)	
25	15	11	7	18	18	50 *	50 *	-	-	-	-
25	6	5	3	7	12	50 *	50 *	-	-	-	-
40	40	30	18	48	285	50 *	50 *	-	-	-	-
40	16	12	7	19	20	50 *	50 *	-	-	-	-
50	60	45	27	72	38	50 *	50 *	-	-	-	-
50	24	18	11	29	26	50 *	50 *	-	-	-	-
80	150	113	68	180	58	11	50 *	50 *	50 *	-	-
80	60	45	27	72	38	33	50 *	50 *	50 *	-	-
100	240	180	108	288	72	2	24	27	50 *	-	-
100	96	72	43	115	48	11	50 *	50 *	50 *	-	-
150	500	375	225	600	110	-	-	9	38	50 *	50 *
150	200	150	90	240	72	-	-	25	50 *	50 *	50 *
200	800	600	360	960	136	-	-	-	23	44	50 *
200	320	240	144	384	88	-	-	-	50 *	50 *	50 *
250	1250	938	563	1500	174	-	-	-	10	20	50 *
250	500	375	225	600	110	-	-	-	29	50 *	50 *
300	1800	1350	810	2160	200	-	-	-	5	12	44
300	720	540	324	864	126	-	-	-	17	34	50 *

* don't exceed the nominal pressure of the flanged end / ** at a setting of 120 % the maximum possible pressure differences are reduced

valve with „soft“ seat (leakage class VI)

mode of action (air to close)

type of actuator - spring range 0,8 - 1,6 bar						99P-I-NT (120 cm ²)		99P-II-NT (240 cm ²)		99P-III-NT (780 cm ²)	
supply pressure (bar)						2,4	4,0	2,4	4,0	2,4	4,0
DN	Kvs 100 %	Kvs 75 %	Kvs 45 %	Kvs ** 120 %	seat mm	maximum allowable pressure difference (bar)		maximum allowable pressure difference (bar)		maximum allowable pressure difference (bar)	
25	15	11	7	18	18	50 *	50 *	-	-	-	-
25	6	5	3	7	12	50 *	50 *	-	-	-	-
40	40	30	18	48	285	50 *	50 *	-	-	-	-
40	16	12	7	19	20	50 *	50 *	-	-	-	-
50	60	45	27	72	38	50 *	50 *	-	-	-	-
50	24	18	11	29	26	50 *	50 *	-	-	-	-
80	150	113	68	180	58	14	50 *	50 *	50 *	-	-
80	60	45	27	72	38	38	50 *	50 *	50 *	-	-
100	240	180	108	288	72	5	27	30	50 *	-	-
100	96	72	43	115	48	15	50 *	50 *	50 *	-	-
150	500	375	225	600	110	-	-	10	40	50 *	50 *
150	200	150	90	240	72	-	-	28	50 *	50 *	50 *
200	800	600	360	960	136	-	-	-	50 *	38	50 *
200	320	240	144	384	88	-	-	-	50 *	50 *	50 *
250	1250	938	563	1500	174	-	-	-	11	18	50 *
250	500	375	225	600	110	-	-	-	30	48 *	50 *
300	1800	1350	810	2160	200	-	-	-	6	11	50 *
300	720	540	324	864	126	-	-	-	19	30	50 *

* don't exceed the nominal pressure of the flanged end

** at a setting of 120 % the maximum possible pressure differences are reduced

functional principle

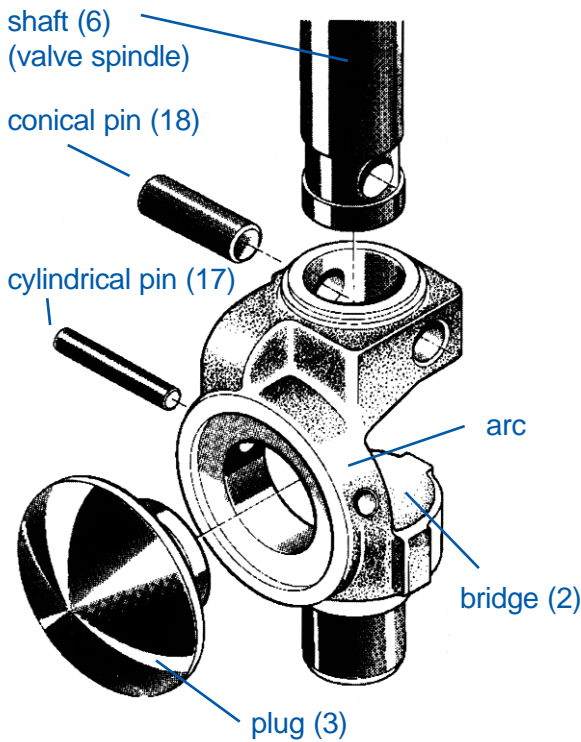

Adjustment of rotation angle of actuator type 99 (patent pending) via system of two levers. Lever (22) attached to diaphragm (24) plate always turns by 30°, hence stroke, pressure range and positioner feedback lever position do not change. With change in setting of bearing pin (27) turn angle of crankshaft (23) (and also valve shaft) changes too, within values 25°, 45°, 60° and 90°, which corresponds with changes in flow ratio values to 45%, 75%, 100% and 120% Kvs. In closed position of valve movement of bearing pin to crankshaft guide at the beginning of lever rotation is parallel, hence closed position of valve is maintained. Connector (35), which connects actuator to valve shaft, allows turning of actuator to valve by each 90°, and since it is accessible from outside it eliminates the need for actuator or valve disassembly. Required position (see Fig. 5) can be set by manufacturer as per customer's request.

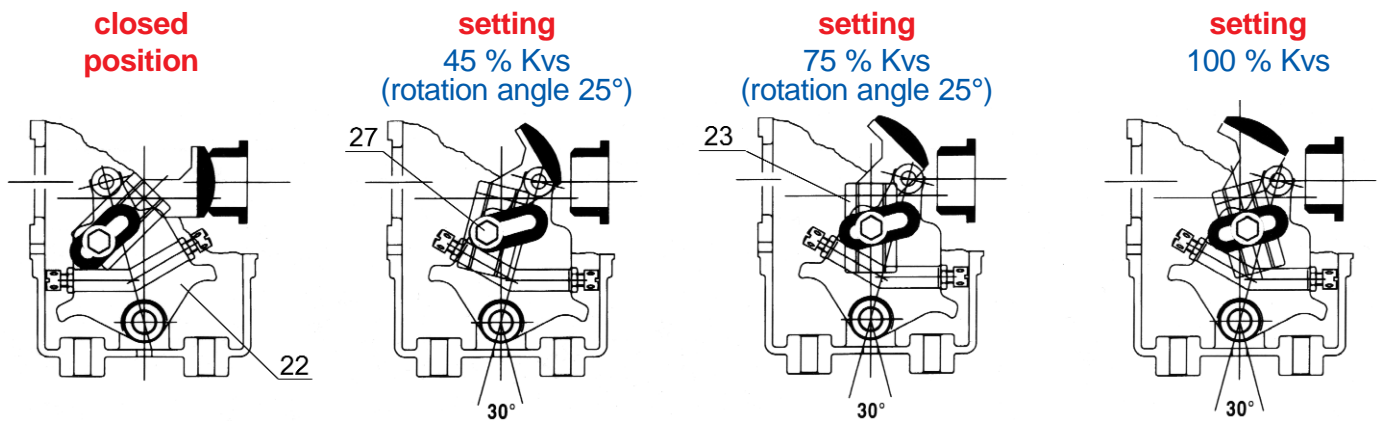
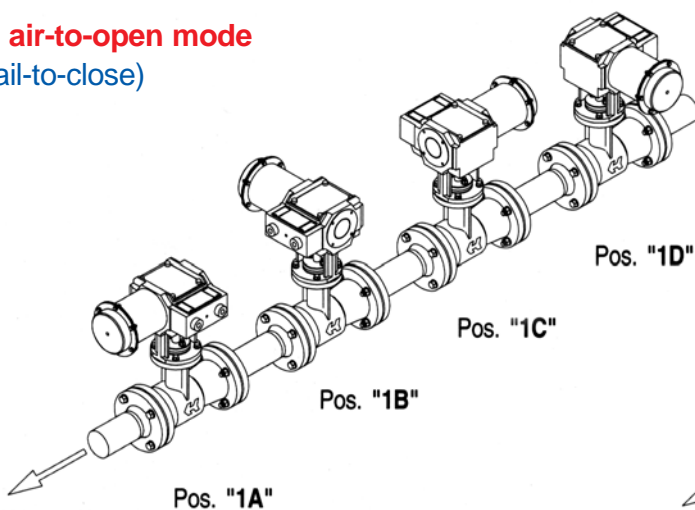

Fig. 4. Bearing pin (27) position on lever (22) regarding crankshaft (23) (valve shaft - Kvs) rotation angle.

The external connector of the actuator makes it possible to rotate the actuator in 90° increments around the valve shaft. This can be done without removing the actuator and to depressurise the pipe (the shaft is blow-out safe). Of course, the required actuator position can also be ordered directly from the factory.

1. air-to-open mode (fail-to-close)



2. air-to-close mode (fail-to-open)

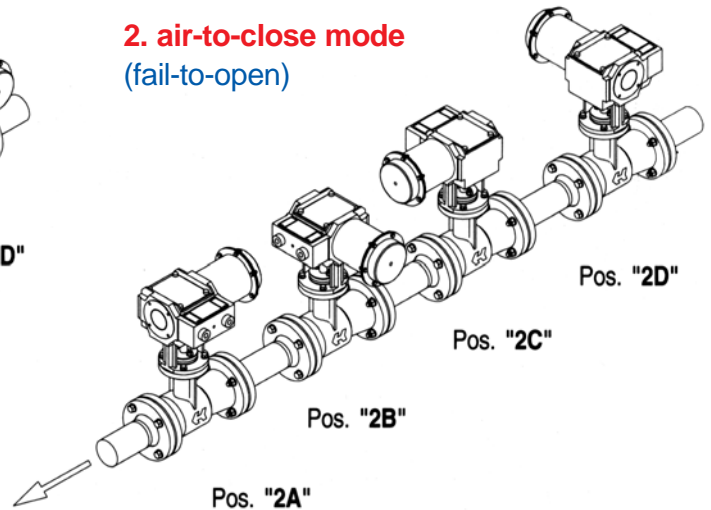

special design variations

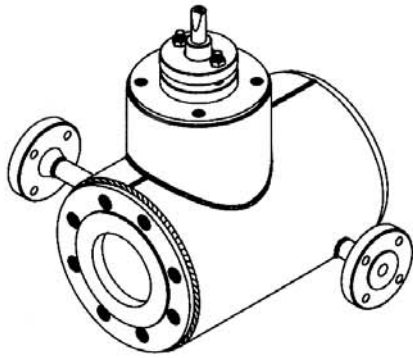

heating jacket

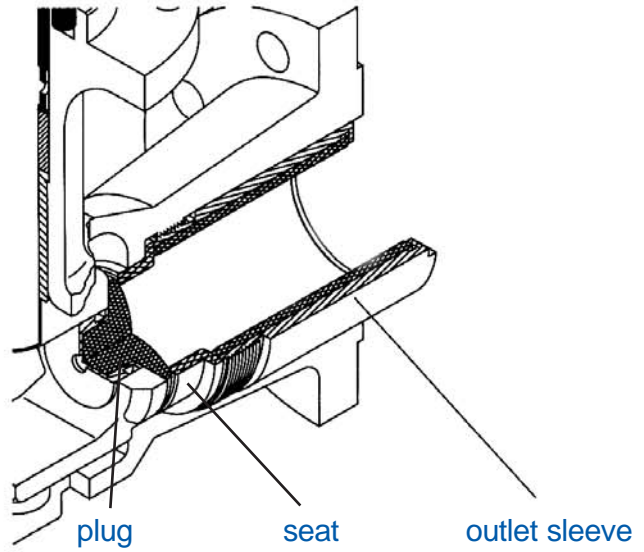

plug, valve seat and outer sleeve
made of ceramic
for highly abrasive media

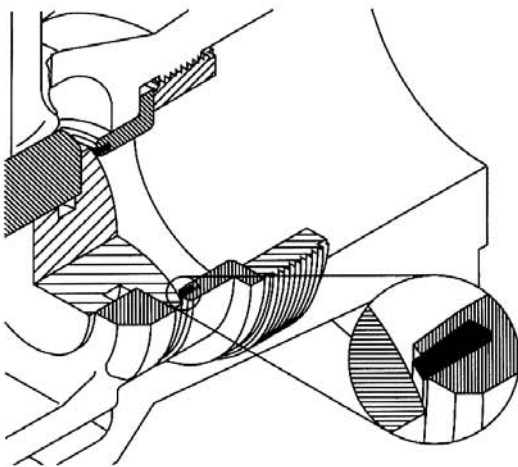

PTFE „soft“ seal
for bubble-tight shut off

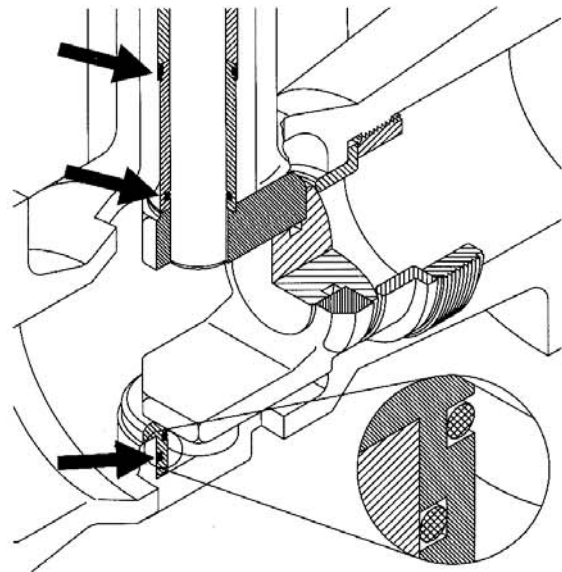

bearing sleeves sealings
for chloride and
chrySTALLIZABLE media

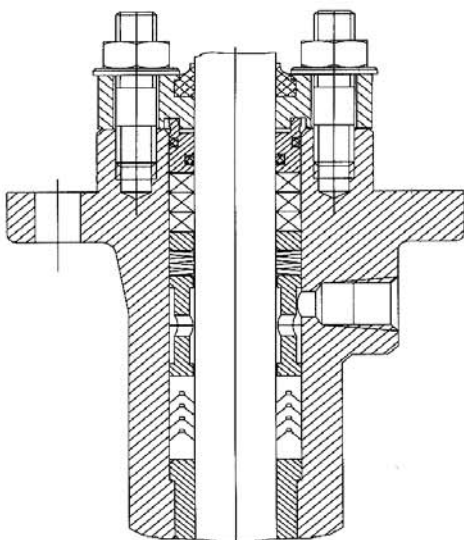

shaft sealing
type TA-Luft

valve drives

Rotary pneumatic valves, diaphragm and spring type 99, with or without a handwheel - special design to drive BR 33 valves.

types of rotary pneumatic actuators

Size	Diaphragm effective area [cm ²]	Spring range [bar]	Rotation angle of output element (crankshaft)
99-I-NT	120	1,0 ... 2,0, 1,6 ... 3,2	25° - 45° - 60° - 90°
99-II-NT	240	0,8 ... 1,6, 1,6 ... 3,2	
99-III-NT	780	1,0 ... 2,0, 1,6 ... 3,2	

actuator characteristics

- total reversibility of action, allowing change in function from „air-to-close - P“ to „air-to-open - R“, with no extra parts
- ability to mount actuator on valve, in various positions, pivoting with 90° increments
- option with a handwheel
- fixed diaphragm effective area, ensuring linear movement to pressure ratio
- optional NAMUR connection

design and technical specification of actuator

body (21)

among the basic components of actuator, designed to hold and assemble other components; executed in grey or spheroidal iron

yoke (28)

connects valve to actuator; executed in grey iron or pressed in steel sheets and welded

diaphragm (25) and spring case (26)

make a pressure chamber and springs case; executed as steel die; welded or cast in spheroidal iron

diaphragm (31)

executed in acrylic-butadiene rubber (NBR); reinforced with nylon insert.

diaphragm plate (24)

formed in plastic or cast in aluminum alloy

lever (22)

transmits plane motion of membrane unit to rotary movement of crankshaft; executed in spheroidal cast-iron

crankshaft (23)

in connection with lever makes an output (driving) element of actuator in the form of rotating pin with key grooves; cast in alloy steel and heat processed.

spring (29)

executed in construction spring steel; 2 springs for range 160 - 320 kPa

bearing pin (27)

connects lever and crankshaft; in special execution (extended) projects from the body and connects actuator to accessories (positioner, limit switches, etc.); executed in alloy steel (stainless steel)

basic technical specification of actuator

- | | | | |
|-------------------------------------|------------------------|-------------------------------------|-------------------------------|
| ● maximum supply pressure | 4,5 bar | ● dead zone | |
| ● control air connection | G 1/4" | with no positioner | 2 % of nominal pressure range |
| ● connection pipes diameter | Ø 6 x 1 (8 x 1) | with positioner | 1 % of nominal pressure range |
| ● ambient temperature range | - 40°C ... + 80°C | ● optional accessories (on request) | |
| ● control pressure change tolerance | | handwheel / positioner / air set / | |
| with no positioner | 4 % of nominal range | three-way solenoid valve / | |
| with positioner | 1,5 % of nominal range | lock-up valve / limit switches / | |
| ● hysteresis deviation | | quick exhaust valve | |
| with no positioner | 4 % of nominal range | | |
| with positioner | 1,5 % of nominal range | | |

rotary pneumatic actuator type 99

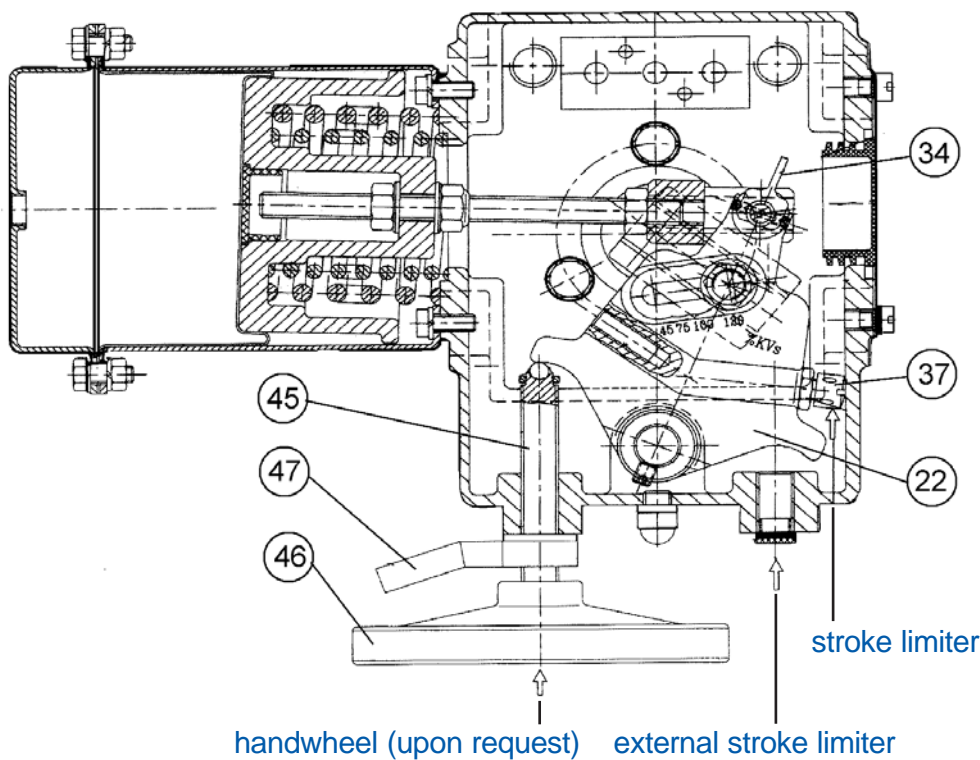
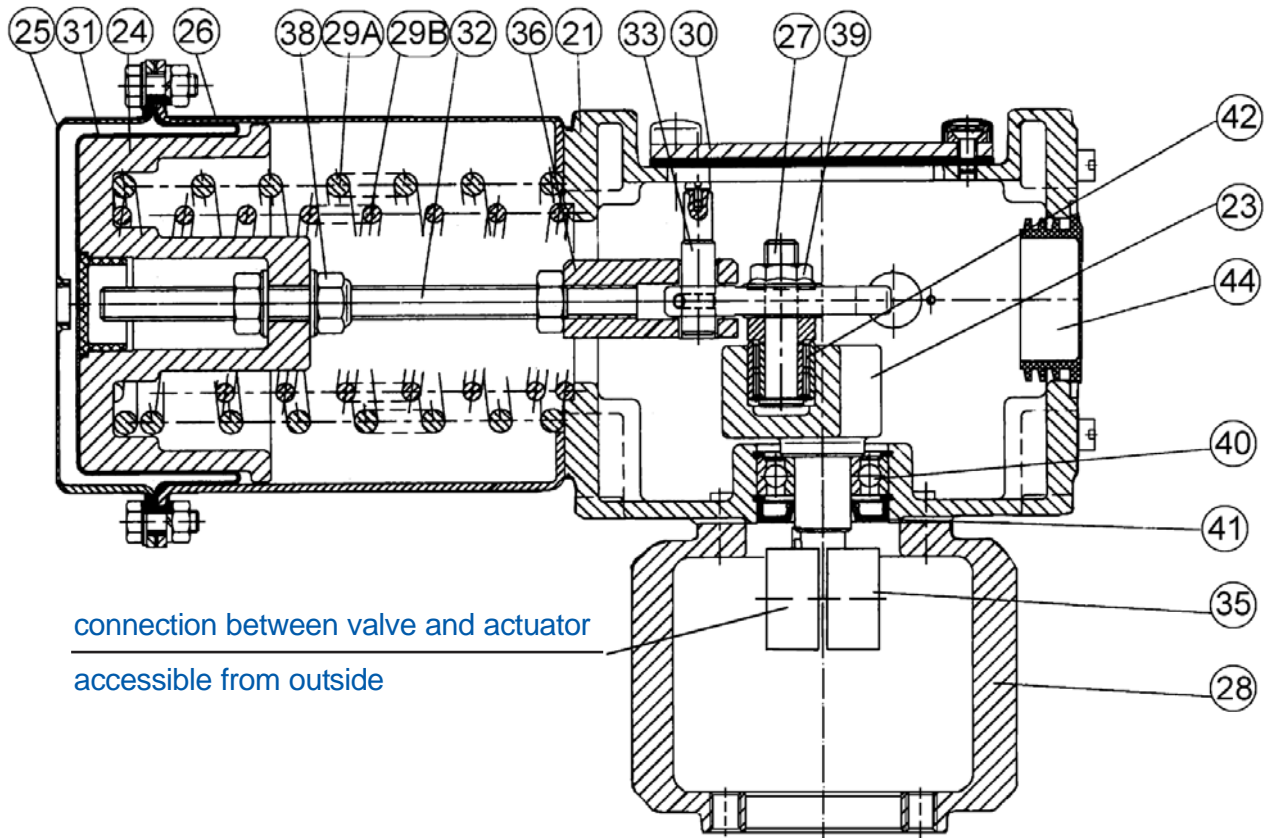

No in fig	Part
21	body
22	lever
23	crankshaft
24	diaphragm plate
25	diaphragm case
26	spring case
27	bearing pin
28	yoke
29	spring (A+B)
30	front nameplate
31	diaphragm
32	screw
33	fork pin
34	stroke indicator
35	connector
36	fork
37	stroke limiter
38	adjusting nut
39	securing nut
40	ball bearing
41	sealing ring
42	needle bearing
44	closure plug
45	handwheel screw
46	wheel
47	counterlever

 = Spare part

external sizes, end connection sizes, weights

valve end connection sizes

DN	End connection as per ISO 5211	E	F	G
25 ... 50	F07	83	16	55
80 ... 100	F12	83	16	85
		116	28	
150	F14	113	28	100
		123	36	

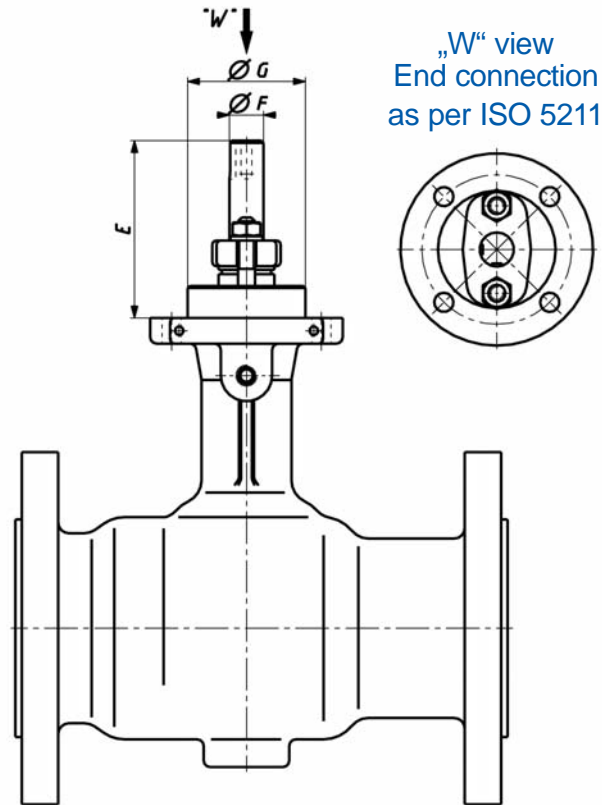

valve end connection sizes

Size	End connection as per ISO 5211	L	K	G ^{+0.5} / _{+0.3}	F	S	Weight [kg]
99-I-NT	F07	110	36	55	16	24	18
	F12			85			
99-II-NT	F12	180	60	85	28	60	54
	F14			100			
	F16	200		130			

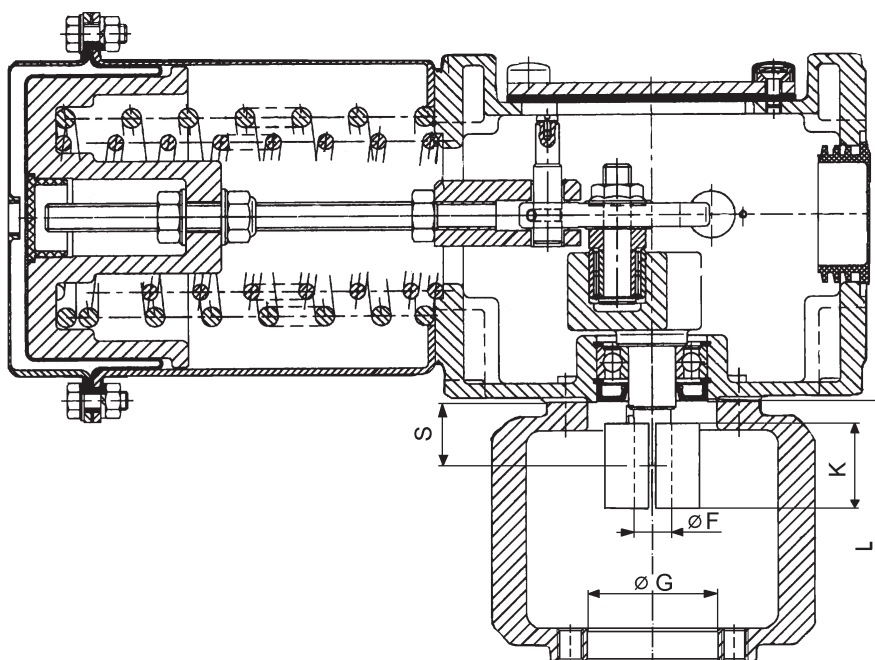

dimensions and weights

DN	flange	actuator	L (mm)	H (mm)	T (mm)	B (mm)	h (mm)	d (mm)	A (mm)	C (mm)	LM (mm)	R (mm)	Q (mm)	V (mm)	weight ¹⁾ (kg)
25	PN 40	99-I-NT	160	409	234	274	134	37	175	55	89	92	105	90	20
25	CL 150	99-I-NT	184	409	234	274	134	37	175	55	113	92	105	90	20
25	CL 300	99-I-NT	197	409	234	274	134	37	175	55	126	92	105	90	21
25	Sandw.	99-I-NT	102	409	234	274	134	37	175	55	60	92	105	90	18
40	PN 40	99-I-NT	200	415	234	274	140	48	175	64	115	92	105	90	22
40	CL 150	99-I-NT	222	415	234	274	140	48	175	64	137	92	105	90	22
40	CL 300	99-I-NT	235	415	234	274	140	48	175	64	150	92	105	90	23
40	Sandw.	99-I-NT	114	415	234	274	140	48	175	64	64	92	105	90	20
50	PN 40	99-I-NT	230	420	234	274	145	60	175	70	123	92	105	90	23
50	CL 150	99-I-NT	255	420	234	274	145	60	175	70	135	92	105	90	23
50	CL 300	99-I-NT	267	420	234	274	145	60	175	70	141	92	105	90	25
50	Sandw.	99-I-NT	124	420	234	274	145	60	175	70	70	92	105	90	22
80	PN 40	99-I-NT	310	467	234	274	192	88	175	90	190	92	105	90	34
80	PN 40	99-II-NT	310	607	348	573	192	88	250	90	190	135	143	75	55
80	CL 150	99-I-NT	298	467	234	274	192	88	175	90	178	92	105	90	34
80	CL 150	99-II-NT	298	607	348	573	192	88	250	90	178	135	143	75	55
80	CL 300	99-I-NT	318	467	234	274	192	88	175	90	197	92	105	90	39
80	CL 300	99-II-NT	318	607	348	573	192	88	250	90	197	135	143	75	60
80	Sandw.	99-I-NT	165	467	234	274	192	88	175	90	92	92	105	90	31
80	Sandw.	99-II-NT	165	607	348	573	192	88	250	90	92	135	143	75	52
100	PN 40	99-I-NT	350	477	234	274	202	107	175	103	215	92	105	90	55
100	PN 40	99-II-NT	350	617	348	573	202	107	250	103	215	135	143	75	76
100	CL 150	99-I-NT	353	477	234	274	202	107	175	103	223	92	105	90	55
100	CL 150	99-II-NT	353	617	348	573	202	107	250	103	223	135	143	75	76
100	CL 300	99-I-NT	368	477	234	274	202	107	175	103	234	92	105	90	65
100	CL 300	99-II-NT	368	617	348	573	202	107	250	103	234	135	143	75	86
100	Sandw.	99-I-NT	194	477	234	274	202	107	175	103	116	92	105	90	51
100	Sandw.	99-II-NT	194	617	348	573	202	107	250	103	116	135	143	75	72
150	PN 40	99-II-NT	480	699	348	573	284	162	250	195	270	135	143	75	100
150	PN 40	99-III-NT	480	789	526	925	284	162	430	195	270	220	230	90	190
150	CL 150	99-II-NT	451	699	348	573	284	162	250	195	241	135	143	75	190
150	CL 150	99-III-NT	451	789	526	925	284	162	430	195	241	220	230	70	190
150	CL 300	99-II-NT	473	699	348	573	284	162	250	195	263	135	143	75	114
150	CL 300	99-III-NT	473	789	526	925	284	162	430	195	263	220	230	70	204
150	Sandw.	99-I-NT	229	699	348	573	284	162	250	195	140	135	143	75	82
150	Sandw.	99-III-NT	229	789	526	925	284	162	430	195	140	220	230	70	172
200	PN 40	99-II-NT	600	727	348	573	312	204	250	216	365	135	143	75	190
200	PN 40	99-III-NT	600	817	526	925	312	204	430	216	365	220	230	70	280
200	CL 150	99-II-NT	543	727	348	573	312	204	250	216	336,5	135	143	75	180
200	CL 150	99-III-NT	543	817	526	925	312	204	430	216	336,5	220	230	70	270
200	CL 300	99-II-NT	568	727	348	573	312	204	250	216	349	135	143	75	210
200	CL 300	99-III-NT	568	817	526	925	312	204	430	216	349	220	230	70	300
200	Sandw.	99-II-NT	243	727	348	573	312	204	250	216	157	135	143	75	130
200	Sandw.	99-III-NT	243	817	526	925	312	204	430	216	157	220	230	70	220
250	PN 40	99-II-NT	730	751	348	573	336	250	250	250	430	135	143	75	230
250	PN 40	99-III-NT	730	841	526	925	336	250	430	250	430	220	230	70	320
250	CL 150	99-II-NT	673	751	348	573	336	250	250	250	401,5	135	143	75	200
250	CL 150	99-III-NT	673	841	526	925	336	250	430	250	401,5	220	230	70	290
250	CL 300	99-II-NT	708	751	348	573	336	250	250	250	421	135	143	75	230
250	CL 300	99-III-NT	708	841	526	925	336	250	430	250	421	220	230	70	320
250	Sandw.	99-III-NT	297	841	526	925	336	250	430	250	190	220	230	70	230
300	PN 40	99-II-NT	850	769	348	573	338	300	250	258	553	135	143	75	430
300	PN 40	99-III-NT	850	859	526	925	338	300	430	258	553	220	230	70	520
300	Sandw.	99-II-NT	338 ²⁾	769	348	573	342	300	250	238	197,5	135	143	75	300
300	Sandw.	99-III-NT	338 ²⁾	859	526	925	342	300	430	238	197,5	220	230	70	390

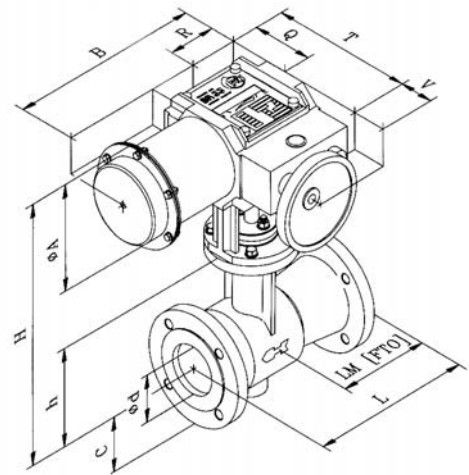

flange configuration
99-I-NT actuator

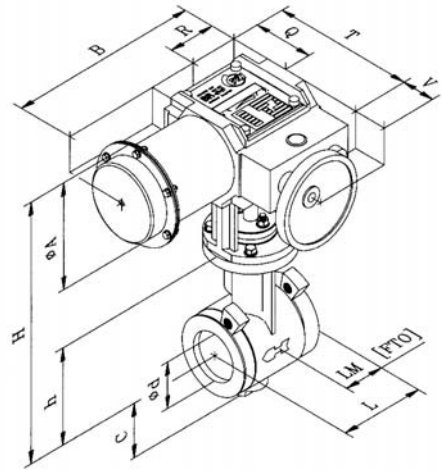

flangeless configuration „sandwich“
99-I-NT actuator

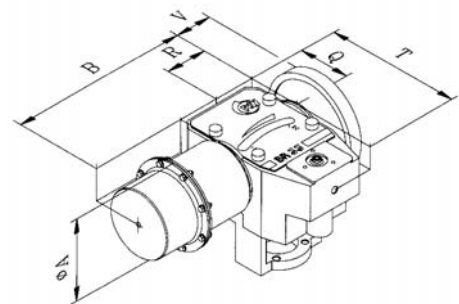

99-II-NT actuator
99-III-NT actuator

1) Valve weight (w/o actuators)
2) Non-compliant with PN-EN 60534-3-2

electric and piston actuators

application

The presented solutions are intended to expand the offer of actuation to cover rotary pneumatic actuators and electric motors that are available on the market in abundant diversity and used by a number of manufacturers.

features

- capable to incorporate alternative drives manufactured with connecting ports to ISO 5211
- wide series of design types and variations
- extensive offer of additional equipments and accessories
- wide range of torque values
- small dimensions
- cost effectiveness in relation to technical performances



dimensional drawing for connections

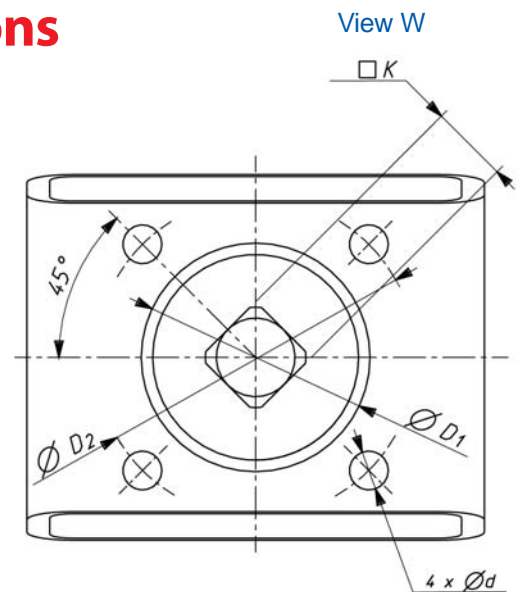
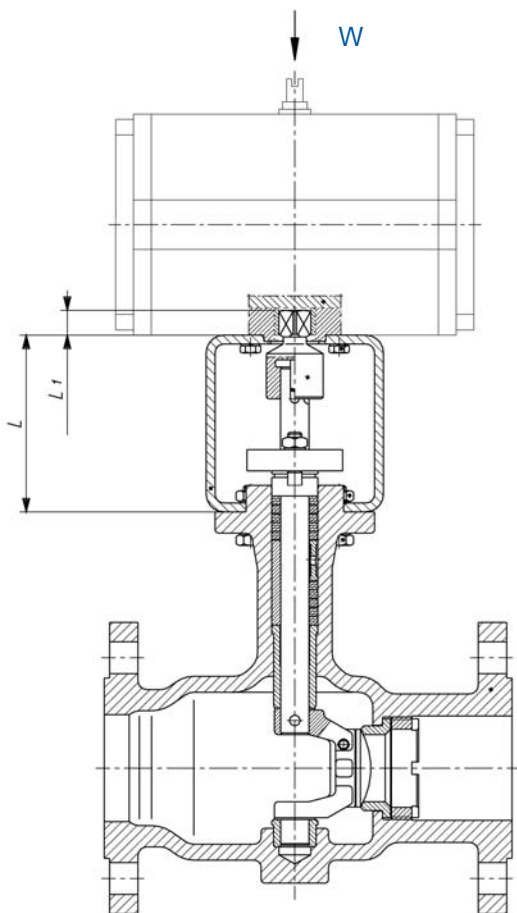

DN	Port type	D ₁	D ₂	d	L	L ₁	K
25...50	F05	35	50	7	100	15	14
	F07	55	70	9		18	17
80...100	F12	85	125	13	130	22	27
					140	37	36
150	F14	100	140	17	140	37	36
						48	46
200...300	F16	130	165	22	140	48	46



**Are you looking
for customer-specific
solutions?**

Ask our specialists

PRE-VENT GmbH

Vertrieb - Produktion - Service
Gewerbepark Lindach A9
84489 Burghausen, Germany

Telefon: +49 8677 98788-0
Telefax: +49 8677 98788-80

E-Mail: office.pre-vent@fiwagroup.com
Internet: www.pre-vent.com

SEITA

Soluciones en Instrumentación,
Automatización y Control Industrial

www.seita.com.co



strong
arguments
of modern technology